

# Instructions – Parts List



WATERBASE COMPATIBLE

# Ultra-lite™ Pistol Grip Flo-Gun

308253N

EN

## Model 235627, Series B

4000 psi (280 bar) Maximum Working Pressure

Tapered Valve Needle

## Model 235628, Series D

6000 psi (415 bar) Maximum Working Pressure

Ball End Valve Needle, Abrasive Material Compatible

## Model 243775, Series B

6000 psi (415 bar) Maximum Working Pressure

Tapered Valve Needle

## Model 237607, Series A

4000 psi (280 bar) Maximum Working Pressure

Tapered Valve Needle, Abrasive Material Compatible

## Model 237649, Series A

4000 psi (280 bar) Maximum Working Pressure

Tapered Valve Needle, Abrasive Material Compatible,  
Swivel Fitting Fluid Inlet

U.S. Patent No. Des. 342,654

Symbols .....	2
Warning .....	2
Technical Data .....	4
Installation .....	5
Operation .....	6
Service .....	8
Parts .....	14
Graco Warranty and Limitation of Liability .....	22
Graco Phone Number .....	22

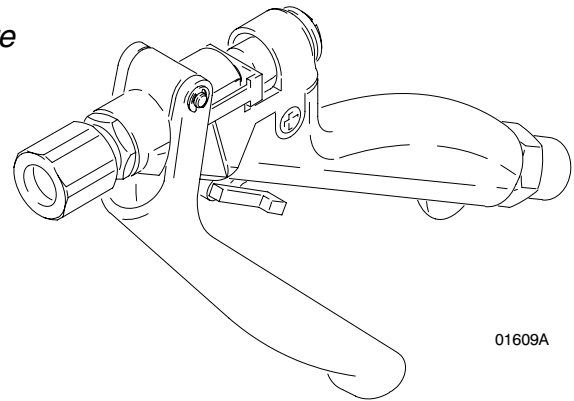

01609A



### Important Safety Instructions

Read all warnings and instructions in this manual.  
Save these instructions.

# Symbols

## Warning Symbol



This symbol alerts you to the possibility of serious injury or death if you do not follow the instructions.

## Caution Symbol



This symbol alerts you to the possibility of damage to or destruction of equipment if you do not follow the instructions.

## ! WARNING



### SKIN INJECTION HAZARD

Spray from the gun, hose leaks, or ruptured components can inject fluid into your body and cause extremely serious injury, including the need for amputation. Splashing fluid in the eyes or on the skin can also cause serious injury.

- Fluid injected into the skin might look like just a cut, but it is a serious injury. **Get immediate surgical treatment.**
- Do not point the gun at anyone or at any part of the body.
- Do not put hand or fingers over the gun nozzle.
- Do not stop or deflect fluid leaks with your hand, body, glove, or rag.
- Be sure the gun trigger safety operates before dispensing.
- Lock the gun trigger safety when you stop dispensing.
- If the nozzle clogs while dispensing, fully release the trigger immediately
- Follow the **Pressure Relief Procedure** on page 6 whenever you: are instructed to relieve pressure; stop spraying; clean, check, or service the equipment; and install or clean the nozzle.
- Tighten all the fluid connections before operating the equipment.
- Check the hoses, tubes, and couplings daily. Replace worn, damaged, or loose parts immediately. Permanently coupled hoses cannot be repaired; replace the entire hose.



### TOXIC FLUID HAZARD

Hazardous fluids or toxic fumes can cause a serious injury or death if splashed in the eyes or on the skin, swallowed, or inhaled.

- Know the specific hazards of the fluid you are using. Read the fluid manufacturer's warnings.
- Store hazardous fluid in an approved container. Dispose of the hazardous fluid according to all local, state, and national guidelines.
- Wear appropriate protective clothing, gloves, eyewear, and respirator.

# WARNING



## FIRE AND EXPLOSION HAZARD

Improper grounding, poor air ventilation, open flames, or sparks can cause a hazardous condition and result in a fire or explosion and serious injury.

- Ground the equipment and the object being sprayed. See **Ground the System** on page 5.
- Provide fresh air ventilation to avoid the buildup of flammable fumes from solvent or the fluid being sprayed.
- Extinguish all the open flames or pilot lights in the spray area.
- Electrically disconnect all the equipment in the spray area.
- Keep the spray area free of debris, including solvent, rags, and gasoline.
- Do not turn on or off any light switch in the spray area while operating or if fumes are present.
- Do not smoke in the spray area.
- Do not operate a gasoline engine in the spray area.
- If there is any static sparking while using the equipment, **stop spraying immediately**. Identify and correct the problem.



INSTRUCTIONS



## EQUIPMENT MISUSE HAZARD

Equipment misuse can cause the equipment to rupture, malfunction, or start unexpectedly and result in a serious injury.

- This equipment is for professional use only.
- Read all the instruction manuals, tags, and labels before operating the equipment.
- Use the equipment only for its intended purpose. If you are uncertain about usage, call your Graco distributor.
- Do not alter or modify this equipment. Use only genuine Graco parts and accessories.
- Check the equipment daily. Repair or replace worn or damaged parts immediately.
- Do not exceed the maximum working pressure of the lowest rated system component. See the front cover or the **Technical Data** for the maximum working pressure of your gun model.
- Route the hoses away from the traffic areas, sharp edges, moving parts, and hot surfaces. Do not expose Graco hoses to temperatures above 180°F (82°C) or below -40°F (-40°C).
- Do not use the hoses to pull the equipment.
- Use only Graco approved hoses. Do not remove hose spring guards, which help protect the hose from rupture caused by kinks or bends near the couplings.
- Use fluids or solvents that are compatible with the equipment wetted parts. See the **Technical Data** section of all the equipment manuals. Read the fluid and solvent manufacturer's warnings.
- Do not use 1,1,1-trichloroethane, methylene chloride, other halogenated hydrocarbon solvents or fluids containing such solvents with gun Models 235627, 237607, and 237649. Such use could result in a serious chemical reaction with the gun's aluminum parts, with the possibility of an explosion.
- Comply with all applicable local, state and national fire, electrical and other safety regulations.

# Technical Data

## Maximum Working Pressure

Models 235627, 237607,  
and 237649 ..... 4000 psi (280 bar)  
Models 235628 and 243775 ... 6000 psi (415 bar)

## Outlet Port Size

All Models ..... 1/4 npt(f) with nut for metal  
flanged nozzle

## Inlet Port Size

Models 235627 and 237607 ..... 1/4 npt(f)  
Models 235628 and 243775 ..... 1/2 npt(f)  
Model 237649 ..... 37° SAE, 1/2-20 UNF(m)

## Valve Orifice

Models 235627, 237607, 243775,  
and 237649 ..... 0.20 in. (5.08 mm) dia.  
with tapered needle  
Model 235628 ..... 0.19 in. (4.83 mm) dia. with  
0.25 in. (6.35 mm) carbide ball

## Height

All Models ..... 5.90 in. (149.86 mm)

## Width

All Models ..... 1.20 in. (30.48 mm)

## Length

Models 235627, 235628, 243775  
and 237607 ..... 8.05 in. (204.47 mm)  
Model 237649 ..... 8.90 in. (226.06 mm)

## Weight

Model 235627 ..... 15.45 oz. (439 g)  
Model 235628 and 243775 ..... 22.70 oz. (636 g)  
Model 237607 ..... 15.45 oz. (439 g)  
Model 237649 ..... 17.00 oz. (483 g)

## Wetted Parts

Model 235627  
Fluid Section ..... Aluminum  
Fluid Tube ..... 300 Series Stainless Steel  
Valve Needle ..... 17-4 PH Stainless Steel  
Valve Seat ..... 17-4 PH Stainless Steel  
Other ... 316 Stainless Steel, fluoroelastomer,  
and Polyurethane

## Model 235628

Fluid Section ..... 17-4 PH Stainless Steel  
Fluid Tube ..... 300 Series Stainless Steel  
Valve Needle ..... Carbide and 17-4 PH  
Stainless Steel  
Valve Seat ..... Carbide and 17-4 PH  
Stainless Steel  
Other . Stainless Steel, fluoroelastomer, PTFE  
;CV75,  
and Polyurethane

## Model 243775

Fluid Section ..... 17-4 PH Stainless Steel  
Fluid Tube ..... 300 Series Stainless Steel  
Valve Needle ..... Carbide and 17-4 PH  
Stainless Steel  
Valve Seat ..... Carbide and 17-4 PH  
Stainless Steel  
Other Stainless Steel, fluoroelastomer, PTFE,  
and Polyurethane

## Model 237607



Fluid Section ..... Aluminum  
Fluid Tube ..... 300 Series Stainless Steel  
Valve Needle ..... Carbide and 17-4 PH  
Stainless Steel  
Valve Seat ..... Carbide and 17-4 PH  
Stainless Steel  
Other ... 316 Stainless Steel, fluoroelastomer,  
and Polyurethane

## Model 237649

Fluid Section ..... Aluminum  
Fluid Tube ..... 300 Series Stainless Steel  
Valve Needle ..... Carbide and 17-4 PH  
Stainless Steel  
Valve Seat ..... Carbide and 17-4 PH  
300 Series Stainless Steel  
Swivel Inlet Fitting ... 303 Stainless Steel, and  
Ultra High Molecular Weight Polyethylene  
Other ... 316 Stainless Steel, fluoroelastomer,  
and Polyurethane

# Installation

## Ground the System

 <b>WARNING</b>	
	<b>FIRE AND EXPLOSION HAZARD</b> To reduce the risk of a fire, explosion, and serious injury, proper electrical grounding of every part of your system is essential. Read the warning section, <b>FIRE AND EXPLOSION HAZARD</b> , on page 3 and follow the grounding instructions below.

The following grounding instructions are minimum requirements for a basic dispensing system. Your system may include other equipment or objects which must be grounded. Check your local electrical code for detailed grounding instructions for your area and type of equipment. Your system must be connected to a true earth ground.

1. **Pump:** ground the pump by connecting a ground wire and clamp as described in your separate pump instruction manual.
2. **Air compressors and hydraulic power supplies:** ground the equipment according to the manufacturer's recommendations.
3. **Fluid hoses:** use only grounded fluid hoses with a maximum of 500 feet (150 m) combined hose length to ensure grounding continuity. Check the electrical resistance of your fluid hoses at least once a week. If your hose does not have a tag on it which specifies the maximum electrical resistance, contact the hose supplier or manufacturer for the maximum resistance limits. If the hose resistance exceeds the recommended limits, replace it immediately.
4. **Flo-gun:** ground the gun by connecting it to a properly grounded fluid hose and pump.
5. **Fluid supply container:** ground according to the local code.
6. **Flammable liquids in the spray area:** must be kept in approved, grounded containers. Do not store more than the quantity needed for one shift.
7. **All solvent pails used when flushing:** ground according to local code. Use only metal pails, which are conductive. Do not place the pail on a non-conductive surface, such as paper or cardboard, which interrupts the grounding continuity.
8. **To maintain grounding continuity when flushing or relieving pressure:** hold a metal part of the gun firmly to the side of a grounded metal pail, then trigger the gun.

# Operation

## Pressure Relief Procedure

### WARNING



#### SKIN INJECTION HAZARD

The system pressure must be manually relieved to prevent the system from starting or spraying accidentally. Fluid under high pressure can be injected through the skin and cause a serious injury. To reduce the risk of an injury from injection, splashing fluid, or moving parts, follow the **Pressure Relief Procedure** whenever you:

- are instructed to relieve the pressure,
- stop dispensing,
- check or service any of the system equipment,
- or install or clean the nozzle.

1. Fully release the gun trigger and lock the gun trigger safety by rotating the safety forward. See Fig. 1.
2. Shut off the fluid supply pump.
3. Hold a metal part of the gun firmly to the side of a grounded metal waste container. Unlock the gun trigger safety by rotating the safety backward. See Fig. 2. Trigger the gun to relieve fluid pressure.
4. Fully release the gun trigger and lock the gun trigger safety by rotating the safety forward.
5. Open the pump drain valve to help relieve fluid pressure in the pump, hose, and gun. Triggering the gun to relieve pressure may not be sufficient. Have a container ready to catch the drainage.
6. Leave the drain valve open until you are ready to dispense again.
7. If you think that the gun nozzle or fluid hose is completely clogged or that pressure has not been fully relieved after following the steps above, very slowly loosen the hose end coupling and relieve pressure gradually, then loosen the coupling completely. Clear the nozzle or hose obstruction.

## Gun Trigger Safety

### WARNING



#### SKIN INJECTION HAZARD

To prevent accidental triggering of the gun and reduce the risk of a serious injury, including fluid injection or splashing in the eyes or on skin, lock the gun trigger safety when you stop dispensing.

*To lock the gun safety, release the trigger and rotate the safety toward the trigger as shown in Fig. 1.*

**NOTE:** Do not try to force the trigger valve open with the safety engaged. This could result in component failure.

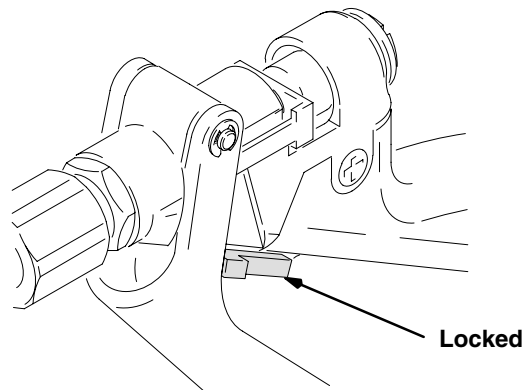

Fig. 1

01610A

*To unlock the trigger safety, rotate the safety toward the handle as shown in Fig. 2.*

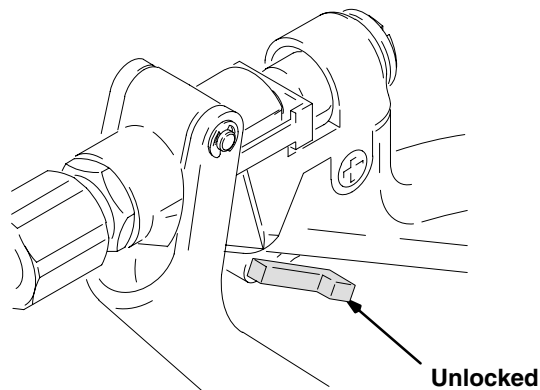

Fig. 2

01610A

# Operation

## Dispensing

1. Start the fluid supply pump.
2. The fluid flow rate is controlled at the pump. Adjust the pump pressure to obtain the desired flow rate. It is recommended that you use the lowest pressure necessary to dispense the fluid. The pressure adjustment will depend on the hose length, the viscosity of the fluid, and the gun nozzle size.
3. Unlock the gun trigger safety.
4. Squeeze the trigger in all the way. Fluid flow begins with the slightest pressure on the trigger and stops when the trigger is released.

**NOTE:** Periodically inspect the vent in the gun handle for fluid buildup which could indicate an internal leak. See Fig. 3. Service the fluid tube and o-ring as needed.

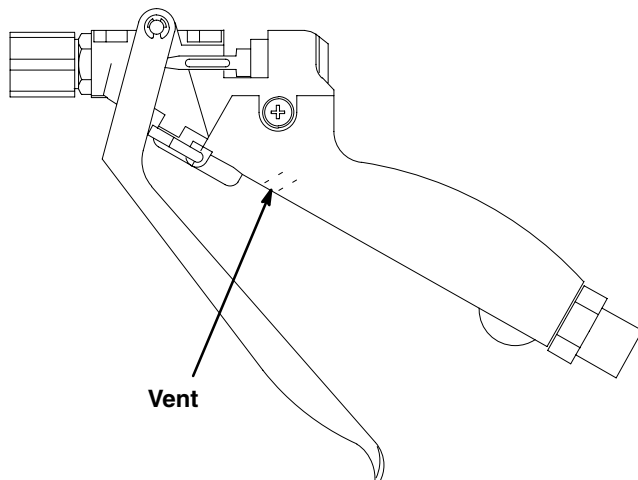

Fig. 3

01807A

## Flushing Safety

### **WARNING**



#### **FIRE AND EXPLOSION HAZARD**

To reduce the risk of a fire, explosion, or serious injury,



- Be sure the entire system and flushing pails are properly grounded before flushing the gun or system.

Read **Grounding the System**, on page 5.

- Use the lowest possible fluid pressure and maintain firm metal-to-metal contact between the gun and the grounded metal pail during flushing.

# Service

## ⚠ WARNING



### SKIN INJECTION HAZARD

To reduce the risk of a serious injury, including fluid injection,

- Follow the **Pressure Relief Procedure** on page 6 when you stop dispensing, before servicing the gun, and whenever you are instructed to relieve the pressure.
- After adjusting or servicing the gun, make sure the fluid will not trigger on when the trigger safety is locked. If fluid does flow, the gun is not assembled properly or the trigger safety is damaged. Reassemble the gun or return it to your nearest Graco distributor. Do not use the gun until the problem is corrected.
- When removing the gun from the hose, hold the hex end of the fluid tube (19) securely to avoid loosening the fluid tube from the gun body. Refer to Fig. 6, page 13.

### SERVICE NOTES:

## ⚠ WARNING



### SKIN INJECTION HAZARD

To reduce the risk of a serious injury, including fluid injection, if fluid continues to flow after the trigger is released, service the gun immediately as instructed below. Do not use the gun until the problem is corrected.

1. The numbers in parentheses in the text refer to reference numbers in the drawings.
2. If the fluid continues to flow after the trigger is released, the gun valve may need adjustment, be obstructed or damaged, or the valve stem (24), seat (26), or seal (3) may be worn or damaged. See Fig. 4, page 11.
  - a. Adjust the valve or the spring tension as instructed on page 9.
  - b. Replace the valve seal, stem, or seat as instructed on page 10.

- c. To inspect the valve for obstruction or damage, disassemble the gun as instructed on page 11. Clean and inspect the parts. Replace any worn or damaged parts and reassemble the gun as instructed on page 11.

3. Follow the torque, sealant and lubrication notes for your gun model number.

4. The following repair kits are available:

Gun Model	Repair Kit	Description
235627	235658*	6.5° needle, seat, urethane seal
	235875	PTFE seal, o-rings only
	235869	20° needle, seat, urethane seal
	237596	7.5° carbide needle, seat, urethane seal
235628	235829*	Carbide ball seat, urethane seal
	235875	PTFE and CV75 seal, o-rings only
243775	237596*	7.5° carbide needle, seat, urethane seal
	235875	PTFE seal, o-rings only
237607	237596*	7.5° carbide needle, seat, urethane seal
	235875	PTFE seal, o-rings only
	235869	20° SST needle, seat, urethane seal
237649	237596*	7.5° carbide needle, seat, urethane seal

\* These are the standard Repair Kits for the gun models. The other kits listed are optional.

**NOTE:** The fluid flow rates of guns using Repair Kits 235658 and 237596 are similar. Kit 235869 will provide increased fluid flow. Kits 235658 and 235869 should not be used to dispense abrasive fluids.



# Service

## Adjusting the Valve

The trigger travel and corresponding valve opening are factory set to 1 inch (25.4 mm). To adjust this setting, follow the procedure below.

**⚠ WARNING**



**SKIN INJECTION HAZARD**  
To reduce the risk of a serious injury, including fluid injection, follow the **Pressure Relief Procedure** on page 6 whenever you are instructed to relieve the pressure.

1. Relieve the pressure in the system.
2. Disconnect the gun from the hose.
3. Using a 5/16 in. wrench, loosen the stem nut (1) and spring housing (28). See Fig. 4, page 11.
4. Insert a 1/8 hex allen wrench through the hole in the spring adjustment screw (21) and into the spring housing (28).

5. Turn the spring housing (28) and stem nut (1) to change the trigger travel and the size of the valve opening.
6. Tighten the stem nut (1) to set the adjustment.
7. Adjust the spring adjustment screw (21) to the desired trigger pull force.

## Adjusting the Spring Tension

**⚠ WARNING**



**SKIN INJECTION HAZARD**  
To reduce the risk of a serious injury, including fluid injection, follow the **Pressure Relief Procedure** on page 6 whenever you are instructed to relieve the pressure.

1. Relieve the pressure in the system.
2. Disconnect the gun from the hose.
3. Turn the spring adjustment screw (21) as needed until the spring force is adjusted to close the valve. Refer to Fig. 4, page 11.

# Service

## Valve Stem and Seal Service

If fluid leaks past the v-block seal (3), the v-block seal or valve stem (24) may be worn or damaged. To replace the seal or valve stem, follow the procedure below.

### **WARNING**



#### **SKIN INJECTION HAZARD**

To reduce the risk of a serious injury, including fluid injection, follow the **Pressure Relief Procedure** on page 6

whenever you are instructed to relieve the pressure.

1. Relieve the pressure in the system.
2. Disconnect the gun from the hose.
3. Unscrew the spring retainer (21) and remove the spring (4). See Fig. 4.
4. Unscrew the spring housing (28) with a 1/8 inch hex allen wrench.
5. Unscrew the valve seat nut (26).
6. Remove the adjustment bracket (20) and stem nut (1) from the stem.
7. Remove the valve stem (24).
8. Remove the seal retainer (27) and seal (3). Replace the seal.
9. Secure the gun body (17) in an assembly fixture.
10. Lubricate the v-block seal (3) and install it into the gun body (17) with the lips of the seal facing into the housing.
11. Lubricate the seal retainer (27). Torque the seal retainer into the gun body (17) to:  
**Models 235627, 237607, and 237649:** 50–60 in-lbs (5.6–6.8 N•m).  
**Models 235628 and 243775:** 100–125 in-lbs (11.3–14.1 N•m).
12. Lubricate the valve stem threads (24) and install it into the gun body (17). Thread the stem assembly through the v-block seal (3).

### **CAUTION**

Installing the valve stem (24) without turning it clockwise could damage the v-block seal and result in fluid leakage.

13. Thread the nut (1) all the way onto the valve stem (24).
14. Install the adjustment bracket (20) and spring housing (28) onto the valve stem (24).
15. Lubricate the threads and o-ring sealing surface on the valve seat nut (26). Torque the valve seat nut into the gun body (17) to:  
**Models 235627, 237607, and 237649:** 70–80 in-lbs (7.9–9.0 N•m).  
**Models 235628 and 243775:** 100–125 in-lbs (11.3–14.1 N•m).
16. Lubricate the spring (4) and spring retainer threads (21) and install them in the gun body (17).
17. Insert a 1/8 inch hex allen wrench through the spring retainer (21) and into the spring housing (28). Adjust the trigger travel and valve opening to the desired position.
18. Using a 5/16 inch wrench, tighten the stem nut (1) to set the adjustment.
19. Adjust the spring adjustment screw (21) to the desired trigger pull force.

# Service

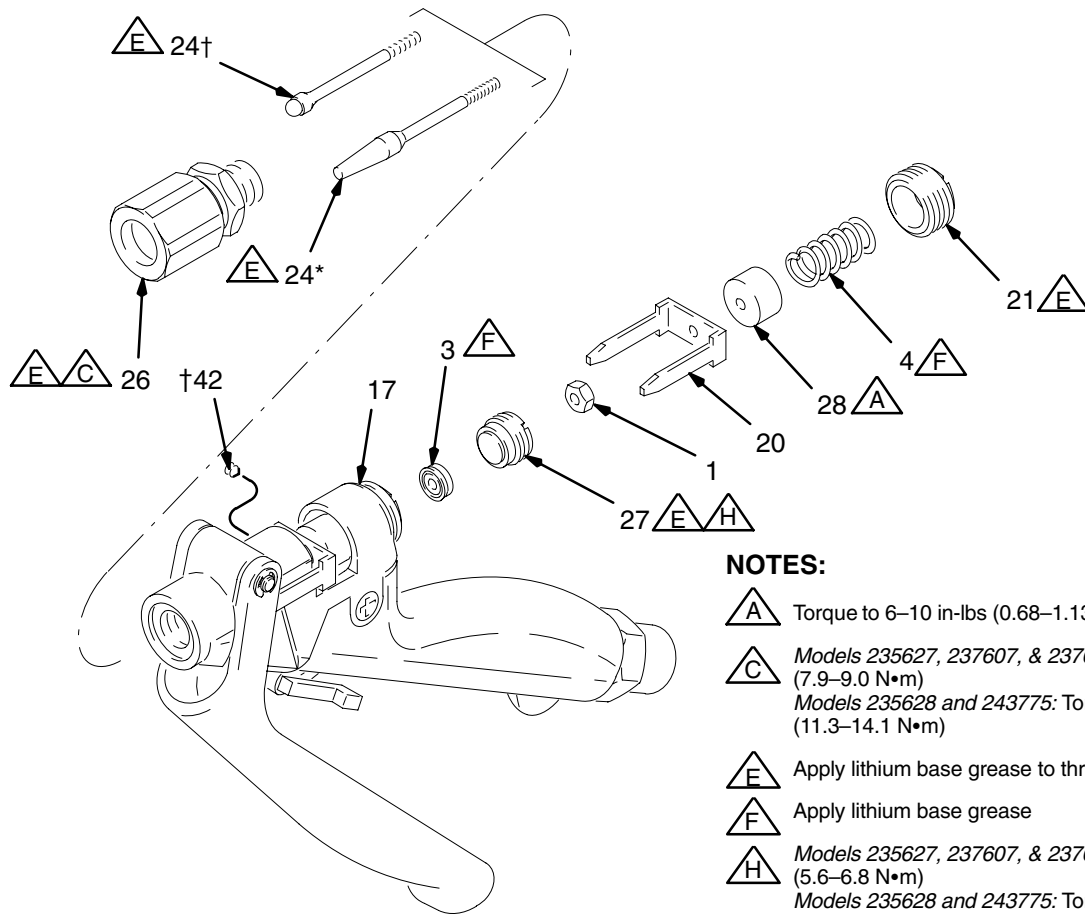

## NOTES:

- A** Torque to 6–10 in-lbs (0.68–1.13 N•m)
- C** *Models 235627, 237607, & 237649:* Torque to 70–80 in-lbs (7.9–9.0 N•m)  
*Models 235628 and 243775:* Torque to 100–125 in-lbs (11.3–14.1 N•m)
- E** Apply lithium base grease to threads
- F** Apply lithium base grease
- H** *Models 235627, 237607, & 237649:* Torque to 50–60 in-lbs (5.6–6.8 N•m)  
*Models 235628 and 243775:* Torque to 100–125 in-lbs (11.3–14.1 N•m)
- \* *Models 235627, 237607, and 237649*
- † *Models 235628 and 243775*

Fig. 4

04809A

## Complete Disassembly and Assembly of the Gun

**⚠ WARNING**

**SKIN INJECTION HAZARD**  
To reduce the risk of a serious injury, including fluid injection, follow the **Pressure Relief Procedure** on page 6 whenever you are instructed to relieve the pressure.

### Disassembly

1. Follow steps 1 to 7 under **Valve Stem and Seal Service**. Be sure to relieve the system pressure before beginning to service the gun.
2. Remove the trigger retaining rings (8), rod (13), and the trigger (29). See Fig. 6, page 13.
3. **Models 235627 and 237607:** unscrew the fluid tube (19) from the gun body (17).  
  
**Models 235628 and 243775:** unscrew the set-screw (42), then unscrew the fluid tube (19) from the gun body (17).
4. **Model 237649:** if necessary for replacement of parts, unscrew the inlet fitting (19) from the fluid tube (18).
5. Remove the gun handle screws (9), gun handle (14), trigger lock (15), ball (2) and spring (7).
6. Remove the seal retainer (27), seal (3), and o-rings (5 and 6).

**⚠ CAUTION**

To avoid loosening the connections and damaging the gun, grip the gun body (17), not the handle (14), when removing the fluid tube (19).

# Service

## Complete Disassembly and Assembly of the Gun (continued)

### Assembly

1. Follow steps 9 to 11 on page 10.
2. Lubricate the o-rings (5 and 6) and install them into the gun body.
3. Follow steps 12 to 14 on page 10.
4. Lubricate the trigger pivot holes (a) bracket guide (b), and rod (13).
5. Install the trigger (29) with the rod (13) and retaining rings (8).
6. Lubricate the thread and o-ring sealing surface on the valve seat nut (26). Torque the valve seat nut into the gun body (17) to:  
**Models 235627, 237607, and 237649:** 70–80 in-lbs (7.9–9.0 N•m).  
**Models 235628 and 243775:** 100–125 in-lbs (11.3–14.1 N•m).
7. Lubricate the trigger lock housing area (c) and apply low strength anaerobic sealant to the screws (9). See Fig. 5.
8. Install the spring (7) into the gun body (17). Place the ball (2) in the center of the spring.
9. Align the trigger lock detent (d) with the ball (2). Compress the ball (2) and spring (7) with the trigger lock (15) until the trigger lock is seated in the housing.
10. While holding the trigger lock (15) in place, install the gun handle (14). Secure the gun handle with the screws (9). Torque the screws to 6–10 in-lbs (7.9–9.0 N•m).
11. For model 237649, if the inlet fitting (19) and fluid tube (18) were disassembled, apply pipe thread sealant compound to the inlet fitting (19). Install the inlet fitting into the fluid tube (18). Torque the fitting to 110–130 in-lbs (12.4–14.7 N•m).

12. Install the fluid tube (19) through the gun handle (14) and screw it into the gun body (17). Torque the fluid tube (19) to:  
**Models 235627, 237607, and 237649:** 50–60 in-lbs (5.6–6.8 N•m).  
**Models 235628 and 243775:** 200–250 in-lbs (22.6–28.2 N•m). Secure the fluid tube with the setscrew (42), and torque the setscrew to 6–10 in-lbs (0.7–1.13 N•m).

### CAUTION

To avoid loosening the connections and damaging the gun, grip the gun body (17), not the handle (14), when tightening the fluid tube (19).

13. Adjust the free travel of the trigger as instructed under **Adjusting the Valve**, page 9.
14. Follow steps 15 to 19 on page 10 to finish assembling the gun.

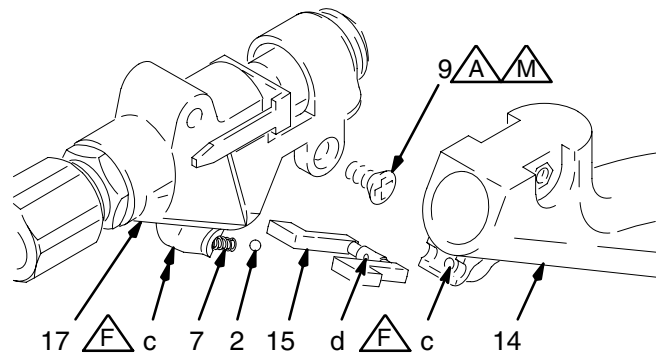

### NOTES:

- A Torque to 6–10 in-lbs (0.68–1.13 N•m)
- F Apply lithium base grease
- M Apply low strength anaerobic sealant (*blue*)

Fig. 5

01806

# Service

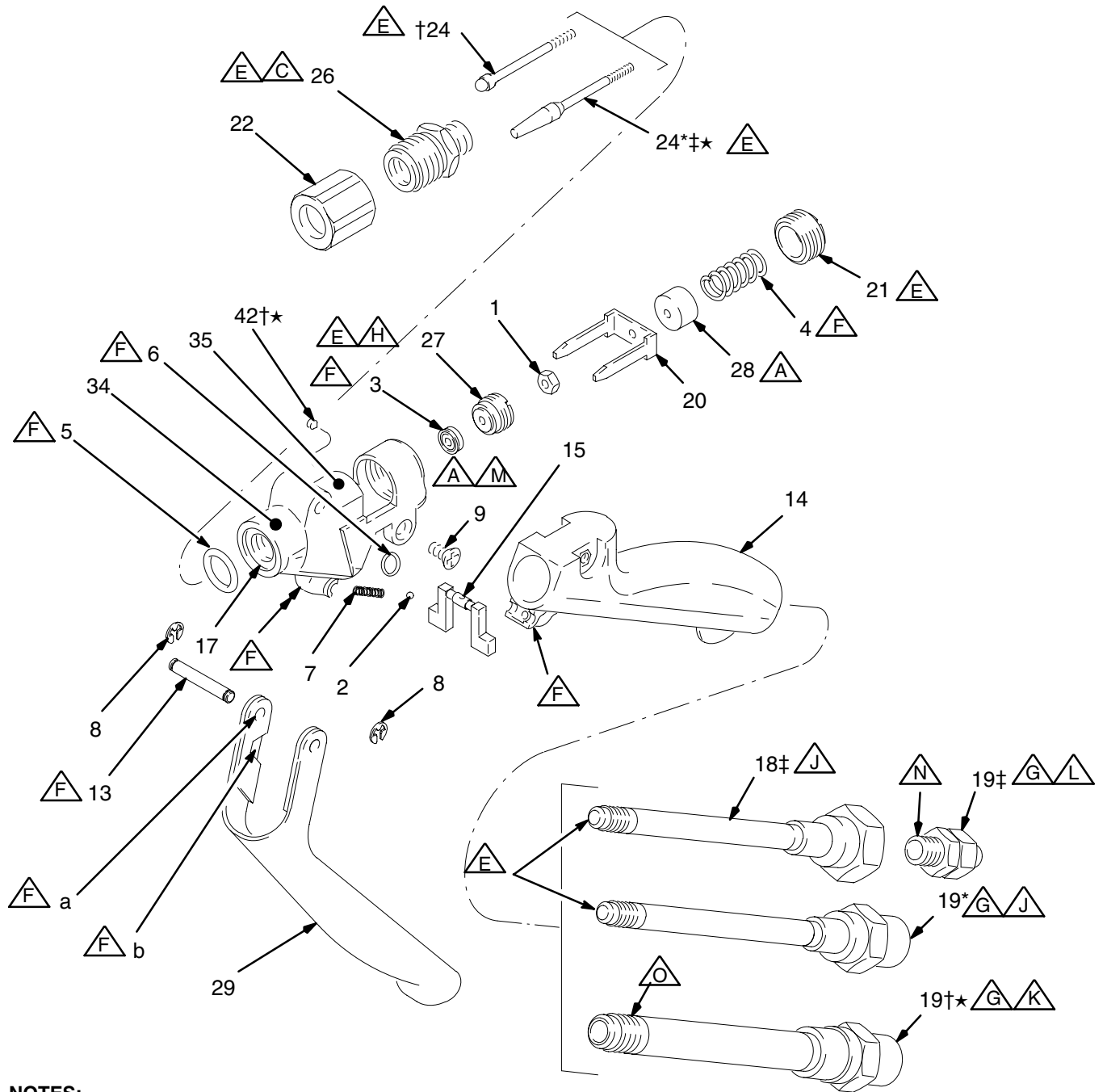

## NOTES:

- |  |   |
|--|---|
| <p><b>A</b> Torque to 6–10 in-lbs (0.68–1.13 N•m)</p> <p><b>C</b> Models 235627, 237607, &amp; 237649: Torque to 70–80 in-lbs (7.9–9.0 N•m)<br/>Models 235628 and 243775: Torque to 100–125 in-lbs (11.3–14.1 N•m)</p> <p><b>E</b> Apply lithium base grease to threads</p> <p><b>F</b> Apply lithium base grease</p> <p><b>G</b> When removing fluid hose, use wrench on end of fluid tube (19) hex to avoid loosening fluid tube (19)</p> <p><b>H</b> Models 235627, 237607, &amp; 237649: Torque to 50–60 in-lbs (5.6–6.8 N•m)<br/>Models 235628 and 243775: Torque to 100–125 in-lbs (11.3–14.1 N•m)</p> | <p><b>J</b> Torque to 50–60 in-lbs (5.6–6.8 N•m)</p> <p><b>K</b> Torque to 200–250 in-lbs (22.6–28.2 N•m)</p> <p><b>L</b> Torque to 110–130 in-lbs (12.4–14.7 N•m). Use the hex end of the fluid tube (18) to reach the swivel fitting (19) torque</p> <p><b>M</b> Apply low strength anaerobic sealant (blue)</p> <p><b>N</b> Apply pipe thread sealing compound to threads</p> <p><b>O</b> Apply anti-seize lubricant to threads</p> <p>* Models 235627 and 237607</p> <p>† Model 235628</p> <p>‡ Model 237649</p> <p>*† Model 243775</p> |
|--|---|

Fig. 6

# Parts

Models 235627 and 237607

Pistol Grip Flow Gun

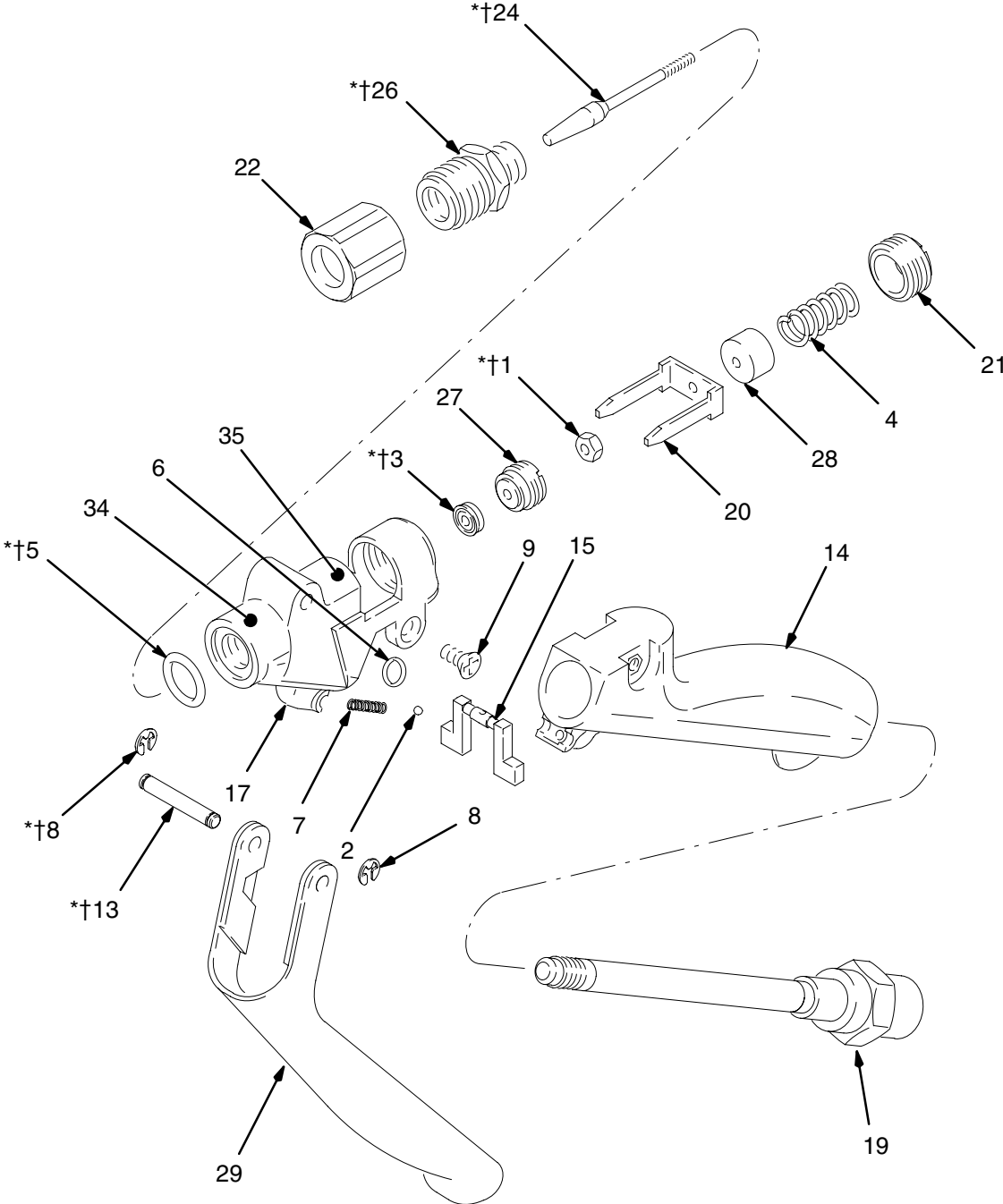

05446

# Parts

## Model 235627

Pistol Grip Flow Gun

Ref. No.	Part No.	Description	Qty.
1*	100975	NUT, hex; No. 5–40	1
2	102233	BALL	1
3*	102921	SEAL, v-block; polyurethane	1
4	102924	SPRING, compression	1
5*	103338	O-RING; fluoroelastomer	1
6	112085	O-RING; fluoroelastomer	1
7	111902	SPRING, compression	1
8*	112410	RING, retaining	2
9	111904	SCREW, handle; flat head	2
13*	189055	ROD	1
14	188231	HANDLE, plastic	1
15	188232	LOCK, trigger	1
17	188239	HOUSING, fluid; aluminum	1
19	237724	TUBE, fluid, with adapter; 300 series stainless steel	1
20	188246	BRACKET, adjustment	1
21	188247	SCREW, spring adjustment	1
22	188253	NUT, nozzle	1
24*	188836	VALVE STEM; 17–4 PH stainless steel	1
26*	188263	NUT, valve seat; 17–4 PH stainless steel	1
27	188271	RETAINER, seal	1
28	188275	HOUSING, spring	1
29	237604	TRIGGER	1
34▲	188377	LABEL, warning	1
35▲	188378	LABEL, instruction	1

\* These parts are included in Repair Kit 235658, which may be purchased separately. See page 8 for complete Repair Kit list.

▲ Replacement Instruction and Warning labels are available at no cost.

## Model 237607

Pistol Grip Flow Gun

Ref. No.	Part No.	Description	Qty.
1†	100975	NUT, hex; No. 5–40	1
2	102233	BALL	1
3†	102921	SEAL, v-block; polyurethane	1
4	102924	SPRING, compression	1
5†	103338	O-RING; fluoroelastomer	1
6	112085	O-RING; fluoroelastomer	1
7	111902	SPRING, compression	1
8†	112410	RING, retaining	2
9	111904	SCREW, handle; flat head	2
13†	189055	ROD	1
14	188231	HANDLE, plastic	1
15	188232	LOCK, trigger	1
17	188239	HOUSING, fluid; aluminum	1
19	237724	TUBE, fluid, with adapter; 300 series stainless steel	1
20	188246	BRACKET, adjustment	1
21	188247	SCREW, spring adjustment	1
22	188253	NUT, nozzle	1
24†	237576	VALVE STEM; carbide & 17–4 PH stainless steel	1
26†	237577	NUT, valve seat; carbide & 17–4 PH stainless steel	1
27	188271	RETAINER, seal	1
28	188275	HOUSING, spring	1
29	237604	TRIGGER	1
34▲	188377	LABEL, warning	1
35▲	188378	LABEL, instruction	1

† These parts are included in Repair Kit 237596, which may be purchased separately. See page 8 for complete Repair Kit list.

▲ Replacement Instruction and Warning labels are available at no cost.

# Parts

Models 237649

Pistol Grip Flow Gun

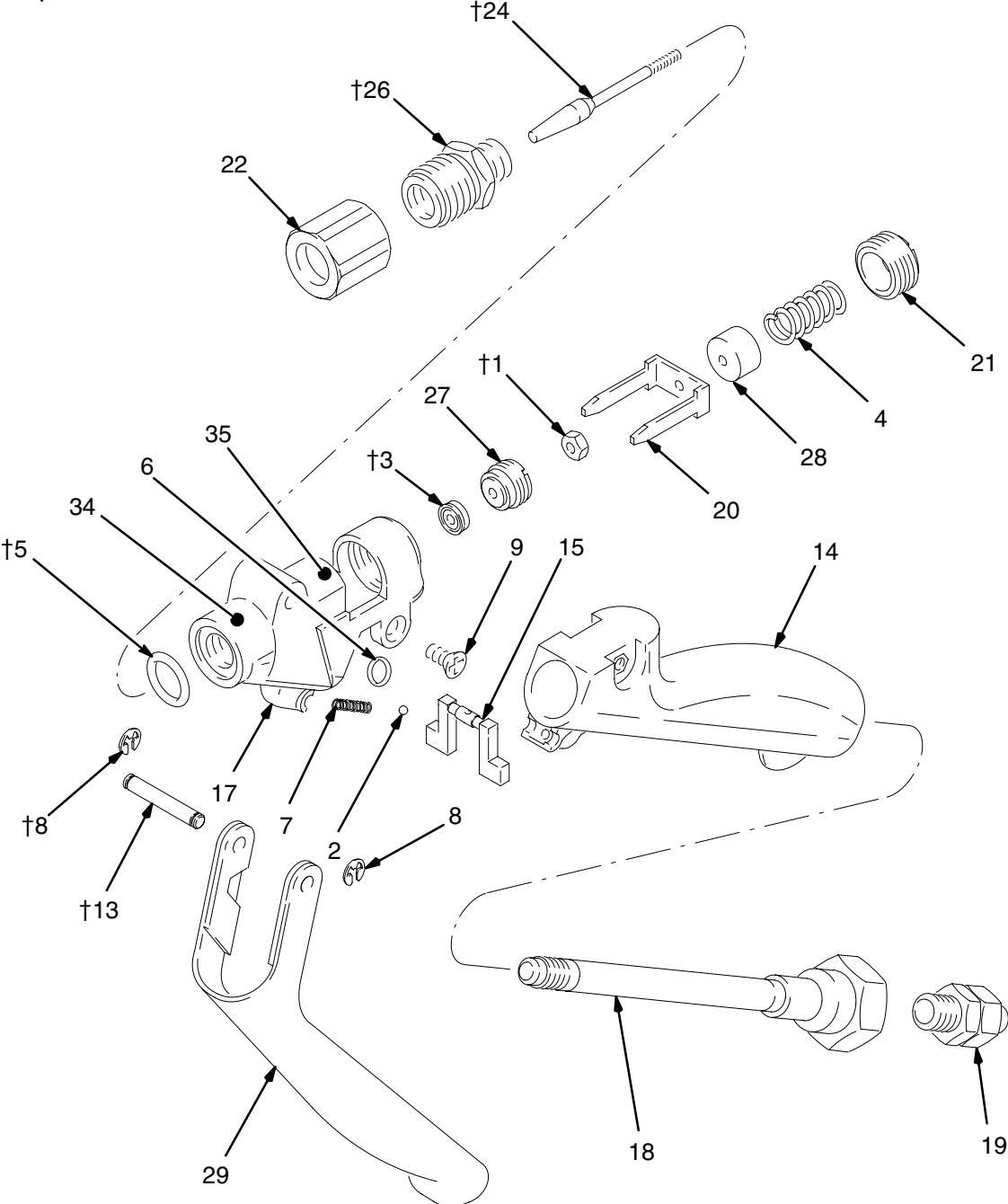

04807



# Parts

## Model 237649

Pistol Grip Flow Gun

Ref. No.	Part No.	Description	Qty.	Ref. No.	Part No.	Description	Qty.
				20	188246	BRACKET, adjustment	1
				21	188247	SCREW, spring adjustment	1
				22	188253	NUT, nozzle	1
1†	100975	NUT, hex; No. 5–40	1	24†	237576	VALVE STEM; carbide & 17–4 PH stainless steel	1
2	102233	BALL	1				
3†	102921	SEAL, v-block; polyurethane	1	26†	237577	NUT, valve seat; carbide & 17–4 PH stainless steel	1
4	102924	SPRING, compression	1				
5†	103338	O-RING; fluoroelastomer	1	27	188271	RETAINER, seal	1
6	112085	O-RING; fluoroelastomer	1	28	188275	HOUSING, spring	1
7	111902	SPRING, compression	1	29	237604	TRIGGER	1
8†	112410	RING, retaining	2	34▲	188377	LABEL, warning	1
9	111904	SCREW, handle; flat hd	2	35▲	188378	LABEL, instruction	1
13†	189055	ROD	1				
14	188231	HANDLE, plastic	1				
15	188232	LOCK, trigger	1				
17	188239	HOUSING, fluid; aluminum	1				
18	237724	TUBE, fluid; with adapter; 300 series stainless steel	1				
19	237637	FITTING, inlet, swivel; 1/4–18 npt; 316 stainless steel	1				

† These parts are included in Repair Kit 237596, which may be purchased separately. See page 8 for complete Repair Kit list.

▲ Replacement Instruction and Warning labels are available at no cost.

# Parts

Model 235628

Pistol Grip Flow Gun

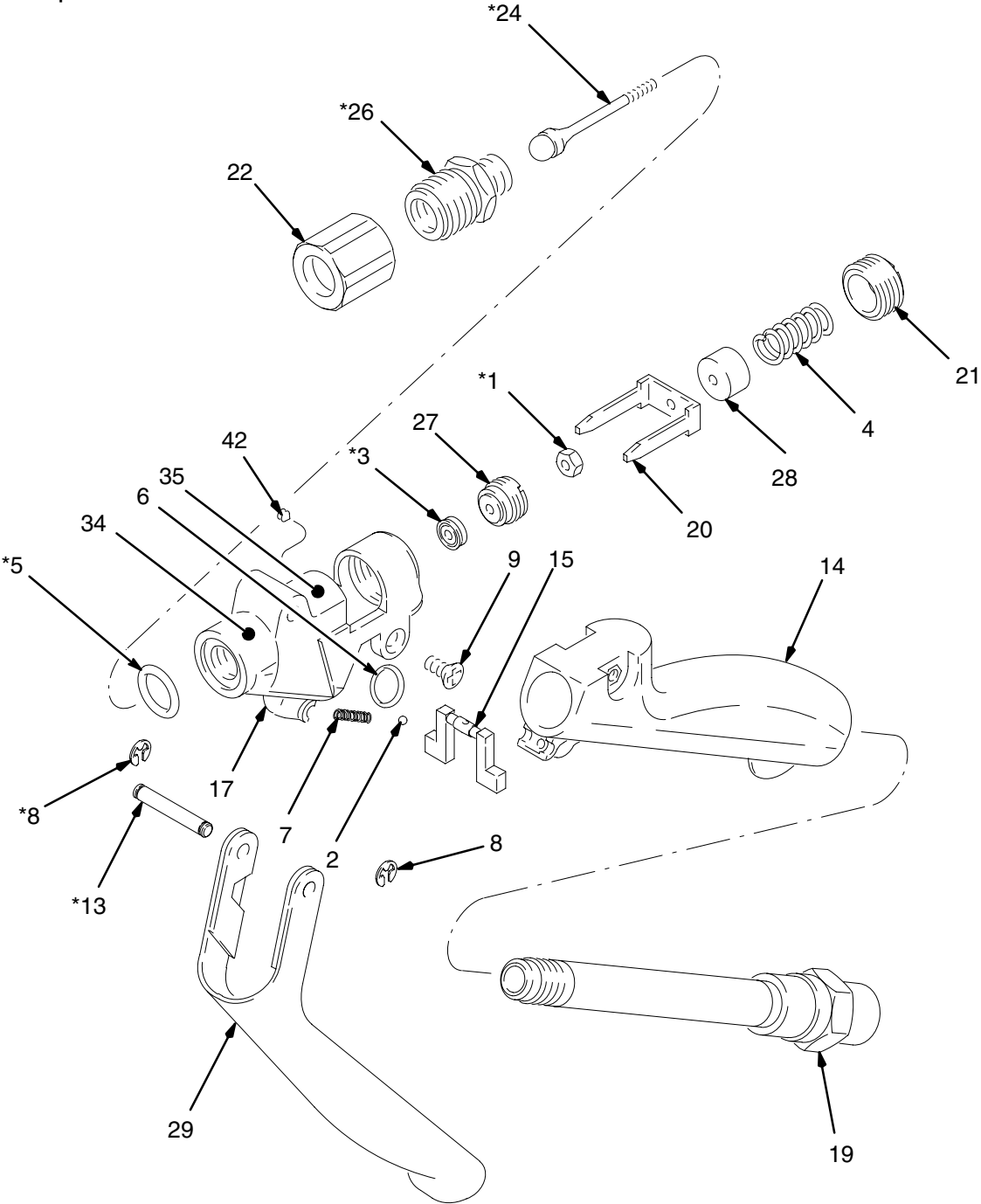

05447A

# Parts

## Model 235628

Pistol Grip Flow Gun

Ref. No.	Part No.	Description	Qty.	Ref. No.	Part No.	Description	Qty.
				20	188246	BRACKET, adjustment	1
				21	188247	SCREW, spring adjustment	1
1*	100975	NUT, hex; No. 5–40	1	22	188253	NUT, nozzle	1
2	102233	BALL; stainless steel	1	24*	236234	STEM, valve	1
3*	102921	SEAL, v-block; polyurethane	1	26*	236235	NUT, seat	1
4	102924	SPRING, compression	1	27	188271	RETAINER, seal	1
5*	102982	O-RING; PTFE	1	28	188275	HOUSING, spring	1
6	111316	O-RING; CV75	1	29	237604	TRIGGER	1
7	111902	SPRING, compression	1	34▲	188377	LABEL, warning	1
8*	112410	RING, retaining	2	35▲	188378	LABEL, instruction	1
9	111904	SCREW, handle; flat hd	2	42	120048	SETSCREW	1
13*	189055	ROD	1				
14	188231	HANDLE, plastic	1				
15	188232	LOCK, trigger	1				
17	188242	HOUSING, fluid; stainless steel	1				
19	237941	TUBE, fluid, with adapter; 300 series stainless steel	1				

\* These parts are included in Repair Kit 235829, which may be purchased separately. See page 8 for complete Repair Kit list.

▲ Replacement Instruction and Warning labels are available at no cost.

# Parts

Model 243775

Pistol Grip Flow Gun

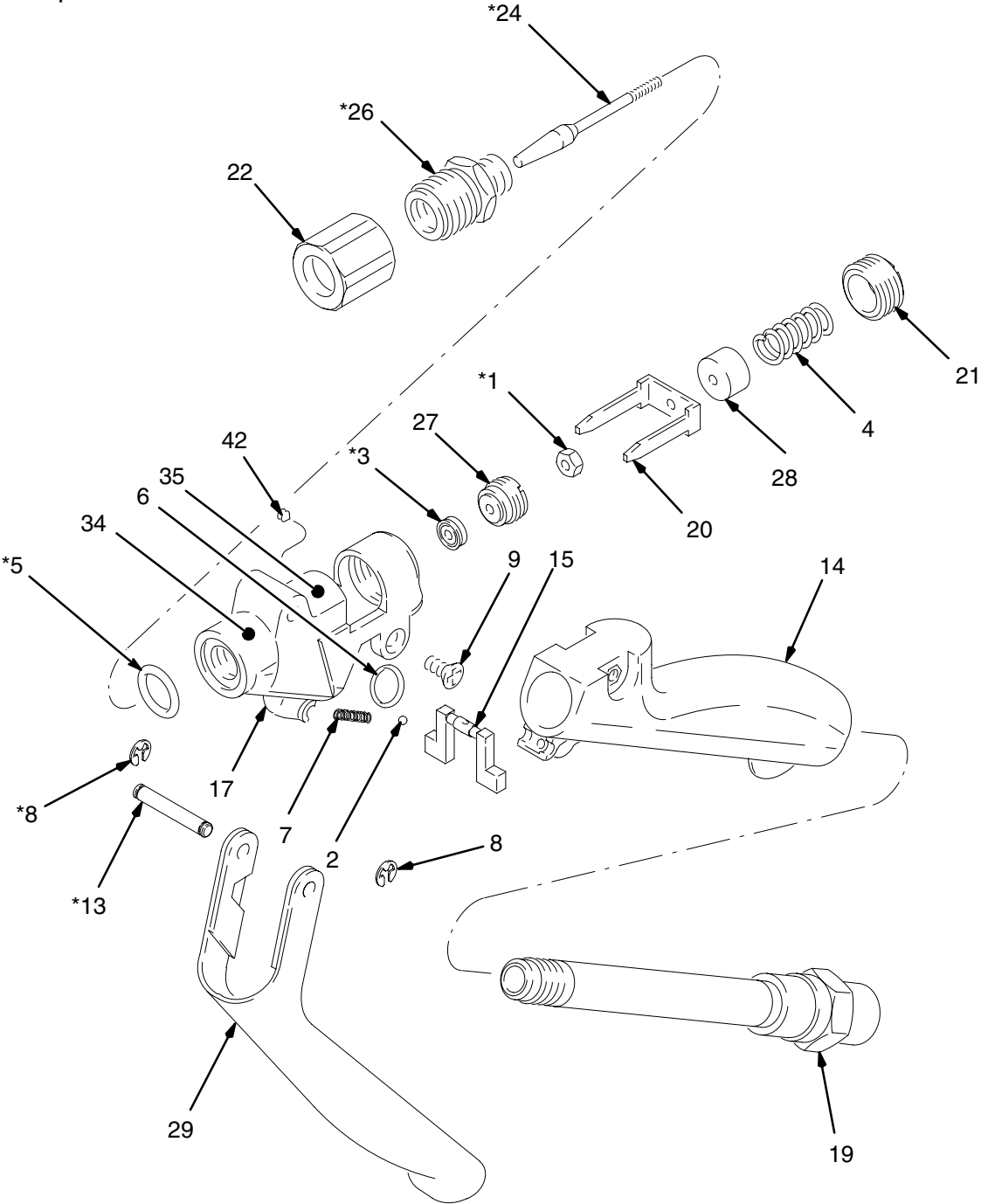

05447A

# Parts

## Model 243775 Pistol Grip Flow Gun

Ref. No.	Part No.	Description	Qty.	Ref. No.	Part No.	Description	Qty.
1*	100975	NUT, hex; No. 5–40	1	21	188247	SCREW, spring adjustment	1
2	102233	BALL; stainless steel	1	22	188253	NUT, nozzle	1
3*	102921	SEAL, v-block; polyurethane	1	24*	237576	VALVE STEM; carbide & 17–4 PH stainless steel	1
4	102924	SPRING, compression	1	26*	237577	NUT, valve seat; carbide & 17–4 PH stainless steel	1
5*	102982	O-RING; PTFE	1	27	188271	RETAINER, seal	1
6	111457	O-RING; PTFE	1	28	188275	HOUSING, spring	1
7	111902	SPRING, compression	1	29	237604	TRIGGER	1
8*	112410	RING, retaining	2	34▲	188377	LABEL, warning	1
9	111904	SCREW, handle; flat hd	2	35▲	188378	LABEL, instruction	1
13*	189055	ROD	1	42	103187	SETSCREW	1
14	188231	HANDLE, plastic	1				
15	188232	LOCK, trigger	1				
17	188242	HOUSING, fluid; stainless steel	1				
19	237941	TUBE, fluid, with adapter; 300 series stainless steel	1				
20	188246	BRACKET, adjustment	1				

\* These parts are included in Repair Kit 237596, which may be purchased separately. See page 8 for complete Repair Kit list.

▲ Replacement Instruction and Warning labels are available at no cost.

# Graco Standard Warranty

Graco warrants all equipment manufactured by Graco and bearing its name to be free from defects in material and workmanship on the date of sale by an authorized Graco distributor to the original purchaser for use. With the exception of any special, extended, or limited warranty published by Graco, Graco will, for a period of twelve months from the date of sale, repair or replace any part of the equipment determined by Graco to be defective. This warranty applies only when the equipment is installed, operated and maintained in accordance with Graco's written recommendations.

This warranty does not cover, and Graco shall not be liable for general wear and tear, or any malfunction, damage or wear caused by faulty installation, misapplication, abrasion, corrosion, inadequate or improper maintenance, negligence, accident, tampering, or substitution of non-Graco component parts. Nor shall Graco be liable for malfunction, damage or wear caused by the incompatibility of Graco equipment with structures, accessories, equipment or materials not supplied by Graco, or the improper design, manufacture, installation, operation or maintenance of structures, accessories, equipment or materials not supplied by Graco.

This warranty is conditioned upon the prepaid return of the equipment claimed to be defective to an authorized Graco distributor for verification of the claimed defect. If the claimed defect is verified, Graco will repair or replace free of charge any defective parts. The equipment will be returned to the original purchaser transportation prepaid. If inspection of the equipment does not disclose any defect in material or workmanship, repairs will be made at a reasonable charge, which charges may include the costs of parts, labor, and transportation.

**THIS WARRANTY IS EXCLUSIVE, AND IS IN LIEU OF ANY OTHER WARRANTIES, EXPRESS OR IMPLIED, INCLUDING BUT NOT LIMITED TO WARRANTY OF MERCHANTABILITY OR WARRANTY OF FITNESS FOR A PARTICULAR PURPOSE.**

Graco's sole obligation and buyer's sole remedy for any breach of warranty shall be as set forth above. The buyer agrees that no other remedy (including, but not limited to, incidental or consequential damages for lost profits, lost sales, injury to person or property, or any other incidental or consequential loss) shall be available. Any action for breach of warranty must be brought within two (2) years of the date of sale.

Graco makes no warranty, and disclaims all implied warranties of merchantability and fitness for a particular purpose in connection with accessories, equipment, materials or components sold but not manufactured by Graco. These items sold, but not manufactured by Graco (such as electric motors, switches, hose, etc.), are subject to the warranty, if any, of their manufacturer. Graco will provide purchaser with reasonable assistance in making any claim for breach of these warranties.

In no event will Graco be liable for indirect, incidental, special or consequential damages resulting from Graco supplying equipment hereunder, or the furnishing, performance, or use of any products or other goods sold hereto, whether due to a breach of contract, breach of warranty, the negligence of Graco, or otherwise.

## **FOR GRACO CANADA CUSTOMERS**

The parties acknowledge that they have required that the present document, as well as all documents, notices and legal proceedings entered into, given or instituted pursuant hereto or relating directly or indirectly hereto, be drawn up in English. Les parties reconnaissent avoir convenu que la rédaction du présente document sera en Anglais, ainsi que tous documents, avis et procédures judiciaires exécutés, donnés ou intentés à la suite de ou en rapport, directement ou indirectement, avec les procédures concernées.

# Graco Phone Number

For the latest information about Graco products, visit [www.graco.com](http://www.graco.com).

**TO PLACE AN ORDER**, contact your Graco distributor, or call this number to identify the distributor closest to you:

**1-800-328-0211 Toll Free**

**612-623-6921**

**612-378-3505 Fax**

*All written and visual data contained in this document reflects the latest product information available at the time of publication. Graco reserves the right to make changes at any time without notice.*

*For patent information, see [www.graco.com/patents](http://www.graco.com/patents).*

Original instructions. This manual contains English. MM 308253

**Graco Headquarters:** Minneapolis

**International Offices:** Belgium, China, Japan, Korea

**GRACO INC. AND SUBSIDIARIES • P.O. BOX 1441 • MINNEAPOLIS MN 55440-1441 • USA**

**Copyright 1992, Graco Inc. All Graco manufacturing locations are registered to ISO 9001.**

[www.graco.com](http://www.graco.com)

Revised January 2013