

SaniForce™ High Sanitation Diaphragm Pumps

Models 1590 HS, 1590 3A, 3150 HS, 3150 3A

310622ZAB

EN

For use in sanitary applications. For professional use only.

See **Models** on page 3 for model numbers, descriptions, and compliance approvals.

120 psi (0.8 MPa, 8 bar) Maximum Fluid Working Pressure

120 psi (0.8 MPa, 8 bar) Maximum Air Input Pressure



Important Safety Instructions. Read all warnings and instructions in this manual. Save these instructions.

See page 2 for Table of Contents.

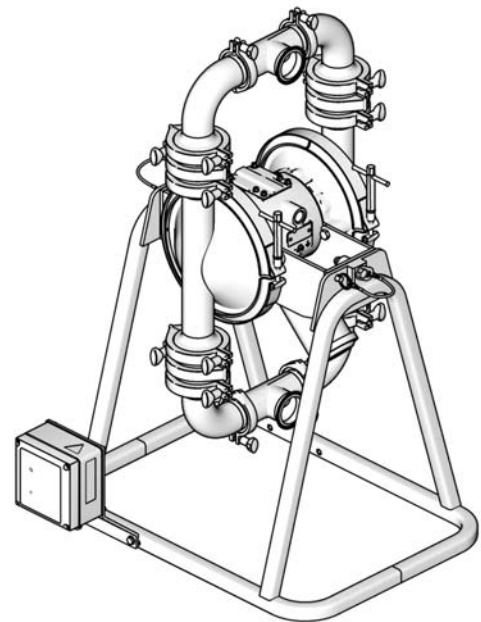







Model SA3AAA Shown

T18760b

Contents

Models	3	Parts List, Air Section and Stand	35
Warnings	5	Air Section - All Models	35
Installation	7	Leak Detector and Pump Stand	35
General Information	7	Kit 24N798, Hinge Repair Kit	35
Leak Detection System	7	Kit 24N799, Quick-Release Pin Repair Kit	35
Tighten Clamps Before First Use	7	Parts List, Models 248273, 248274, 24C124, 24E440, 24E667, 24J388, and 24J389	36
Stand	7	Fluid Section Parts	36
Grounding	7	Ball Check Parts	36
Mountings	8	Flapper Check Parts	36
Air Line	8	Air Section Parts	36
Fluid Suction Line	8	Parts that Vary by Model	37
Fluid Outlet Line	9	Accessories	38
Typical Installation	9	15D990 Leak Detector	38
Changing the Orientation of the Fluid Inlet and Outlet Ports	10	3150 Conversion Kits	38
Air Exhaust Ventilation	11	15H461 3A Approved Ball Check Conversion Kit	38
Operation	12	16E975 Flapper Valve Conversion Kit	38
Pressure Relief Procedure	12	15E285 Sanitary Ball Check Conversion Kit	38
Sanitizing the Pump Before First Use	12	Model 1590 Dimensional Drawing	40
Starting and Adjusting the Pump	12	Model 1590 Technical Data	41
Pump Shutdown	12	Model 1590 Performance Chart	42
Maintenance	13	Model 3150 Dimensional Drawing	43
Lubrication	13	Model 3150 Technical Data	44
Flushing	13	Model 3150 Performance Chart	45
Routine Cleaning of Product Contact Section of Pump	13	Graco Warranties	46
Tightening Connections	13	Graco Standard Pump Warranty	46
Preventive Maintenance Schedule	14	Extended Product Warranty	46
Troubleshooting	15	Graco Information	46
Service	17		
Repairing the Air Valve	17		
Check Valve Repair	20		
Standard Diaphragm Repair	22		
3A/Overmolded Diaphragm Repair	25		
Bearing and Air Gasket Removal	27		
Pump Matrix	29		
SaniForce 3150 Stainless Steel Sanitary Pumps	29		
SaniForce 1590 Stainless Steel Sanitary Pumps	29		
Parts Drawing, Fluid Section	30		
Parts List, Fluid Section	31		
Pump Configuration	31		
Inlet and Outlet	31		
Diaphragm Material	32		
Parts Drawing, Air Section and Stand	34		

Models

Model	Series	Description	Compliance Approvals
* 1590 SABAAA * 3150 SA_AAA	B E	Sanitary Diaphragm Pump	
* 3150 SA_3_1	E	Heavy Duty Sanitary Ball Check Pump	
* 1590 SB____ * 3150 SB__1 * 3150 SB__3	B E D	Sanitary Ball Check Pump	
* 3150 SF__F1 * 3150 SF__F3	F E	Sanitary Flapper Check Pump	
* 1590 SABA13	B	Heavy Duty Sanitary Ball Check Pump	
† 24C124 (for ram and BES mounting)	B	3150 Sanitary Ball Check Pump for Ram systems, with EPDM overmolded diaphragms and PTFE check balls. 24C124 is the same as SA3AA3 except it does not include a fluid inlet tee, elbows, and related parts.	
† 24J388 (for ram mounting)	B	3150 Sanitary Ball Check Pump for Ram systems, with santoprene diaphragms and santoprene check balls. 24J388 is the same as SA3663, except it does not include a fluid inlet tee, elbows, and related parts.	
† 248273 (for BES mounting)	B	3150 Sanitary Ball Check Pump for Bin Evacuation Systems, with santoprene diaphragms and santoprene check balls. 248273 is the same as SB3663 except it does not include a fluid inlet tee, elbows, and related parts.	
† 24E440 (for BES mounting)	B	3150 Sanitary Ball Check Pump for Bin Evacuation Systems, with EPDM overmolded diaphragms and PTFE check balls. 24E440 is the same as SA3AA3 except it does not include a fluid inlet tee, elbows, and related parts. The clamp handles are positioned for use with BES3F3.	
† 24J389 (for ram mounting)	B	3150 Sanitary Ball Check Pump for Ram Systems, with PTFE/EPDM overmolded diaphragms and PTFE check balls. 24J389 is the same as SA33A3 except it does not include a fluid inlet tee, elbows, and related parts.	
† 24E667 (for BES mounting)	B	3150 Sanitary Ball Check Pump for Bin Evacuation Systems, with PTFE/EPDM overmolded diaphragms and santoprene check balls. 24E667 is the same as SB3363 except it does not include a fluid inlet tee, elbows, and related parts.	
† 248274 (for BES mounting)	B	3150 Sanitary Flapper Check Pump for Bin Evacuation Systems, with santoprene diaphragms. 248274 is the same as SF36F3 except it does not include a fluid inlet tee, elbows, and related parts.	

* See **Pump Matrix**, page 28, to determine the part number of configured pumps.

† See pages 36-37 for parts.



Material Certification

Reference: SaniForce Product Family

Issue Date: September 14, 2011

All fluid contact materials in the SaniForce product family are FDA-Compliant and meet the United States Code of Federal Regulations (CFR) Title 21, Section 177 or are of a corrosion resistant grade Stainless Steel. This includes the below product groups:



1. SaniForce 1040, 1590, 2150 Air-Operated Double Diaphragm Pumps
2. SaniForce 1590, 3150 HS Air-Operated Double Diaphragm Pumps
3. SaniForce 1590, 3150 HS 3-A Certified Air-Operated Double Diaphragm Pumps
4. SaniForce 5:1, 6:1 and 12:1 Air-Operated Piston Pumps
5. SaniForce Diaphragm Pump and Piston Pump Drum Unloaders
6. SaniForce Diaphragm Pump and Piston Pump Bin Evacuation Systems

A handwritten signature in black ink that reads 'Bradley A. Byron'.







Bradley A. Byron
Quality Manager
Graco Inc.

Warnings

The following warnings are for the setup, use, grounding, maintenance, and repair of this equipment. The exclamation point symbol alerts you to a general warning and the hazard symbol refers to procedure-specific risk. When these symbols appear in the body of this manual, refer back to these warnings. Additional, product-specific warnings may be found throughout the body of this manual where applicable.

 WARNING	
	<p>FIRE AND EXPLOSION HAZARD</p> <p>Flammable fumes, such as solvent and paint fumes, in work area can ignite or explode. To help prevent fire and explosion:</p> <ul style="list-style-type: none"> • Use equipment only in well ventilated area. • Eliminate all ignition sources; such as pilot lights, cigarettes, portable electric lamps, and plastic drop cloths (potential static arc). • Keep work area free of debris, including solvent, rags and gasoline. • Do not plug or unplug power cords, or turn power or light switches on or off when flammable fumes are present. • Ground all equipment in the work area. See Grounding instructions. • Use only grounded hoses. • Hold gun firmly to side of grounded pail when triggering into pail. • If there is static sparking or you feel a shock, stop operation immediately. Do not use equipment until you identify and correct the problem. • Keep a working fire extinguisher in the work area.
	<p>PRESSURIZED EQUIPMENT HAZARD</p> <p>Fluid from the gun/dispense valve, leaks, or ruptured components can splash in the eyes or on skin and cause serious injury.</p> <ul style="list-style-type: none"> • Follow the Pressure Relief Procedure when you stop spraying and before cleaning, checking, or servicing equipment. • Tighten all fluid connections before operating the equipment. • Check hoses, tubes, and couplings daily. Replace worn or damaged parts immediately.

WARNING

 	<p>EQUIPMENT MISUSE HAZARD</p> <p>Misuse can cause death or serious injury.</p> <ul style="list-style-type: none"> • Do not operate the unit when fatigued or under the influence of drugs or alcohol. • Do not exceed the maximum working pressure or temperature rating of the lowest rated system component. See Technical Data in all equipment manuals. • Use fluids and solvents that are compatible with equipment wetted parts. See Technical Data in all equipment manuals. Read fluid and solvent manufacturer's warnings. For complete information about your material, request MSDS from distributor or retailer. • Do not leave the work area while equipment is energized or under pressure. Turn off all equipment and follow the Pressure Relief Procedure when equipment is not in use. • Check equipment daily. Repair or replace worn or damaged parts immediately with genuine manufacturer's replacement parts only. • Do not alter or modify equipment. • Use equipment only for its intended purpose. Call your distributor for information. • Route hoses and cables away from traffic areas, sharp edges, moving parts, and hot surfaces. • Do not kink or over bend hoses or use hoses to pull equipment. • Keep children and animals away from work area. • Comply with all applicable safety regulations.
 	<p>TOXIC FLUID OR FUMES HAZARD</p> <p>Toxic fluids or fumes can cause serious injury or death if splashed in the eyes or on skin, inhaled, or swallowed.</p> <ul style="list-style-type: none"> • Read MSDSs to know the specific hazards of the fluids you are using. • Route exhaust away from work area. If diaphragm ruptures, fluid may be exhausted into the air. • Store hazardous fluid in approved containers, and dispose of it according to applicable guidelines.
	<p>BURN HAZARD</p> <p>Equipment surfaces and fluid that's heated can become very hot during operation. To avoid severe burns:</p> <ul style="list-style-type: none"> • Do not touch hot fluid or equipment.
	<p>PERSONAL PROTECTIVE EQUIPMENT</p> <p>You must wear appropriate protective equipment when operating, servicing, or when in the operating area of the equipment to help protect you from serious injury, including eye injury, hearing loss, inhalation of toxic fumes, and burns. This equipment includes but is not limited to:</p> <ul style="list-style-type: none"> • Protective eyewear, and hearing protection. • Respirators, protective clothing, and gloves as recommended by the fluid and solvent manufacturer.

Installation

General Information

- The typical installation shown in FIG. 3 is only a guide for selecting and installing system components. Contact your Graco distributor for assistance in planning a system to suit your needs.
- Always use genuine Graco parts and accessories.
- Reference numbers and letters in parentheses refer to the callouts in the figures and the parts lists on pages 30 - 37.

<p>The pump is very heavy (see Technical Data on pages 41 and 44 for specific weights). If the pump must be moved, follow the Pressure Relief Procedure on page 12 and have two people lift the pump by grasping the outlet manifold securely, or use appropriate lifting equipment. Never have one person move or lift the pump.</p>						

Leak Detection System

NOTE: A leak detection system is included with all approved pumps. See manual 311200 included with leak detector for leak detector installation instructions.

Tighten Clamps Before First Use

After you unpack the pump, and before you use it for the first time, check all clamps, and tighten as necessary.

Stand

NOTE: See pages 34 and 35 for parts.

1. Place the stand assembly on a level surface.
2. Mount the pump securely to the brackets using bolts provided.

<p>Keep clear of moving parts.</p>						

NOTE: To drain or service the pump, pull on the quick-release pins (638e, one on each side) to allow the pump to rotate while still securely mounted to the bracket.

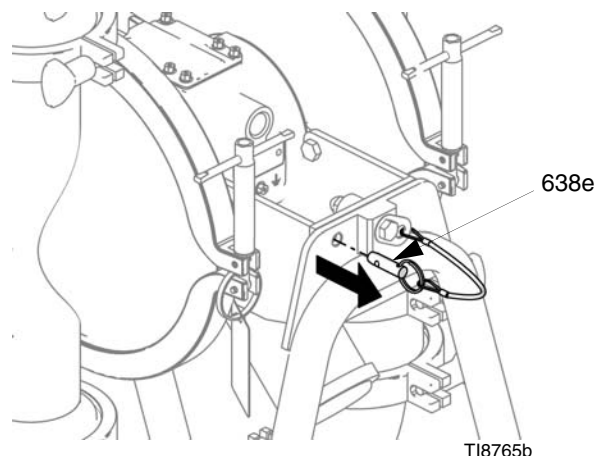

FIG. 1: Quick-release pins for pump rotation

Grounding

<p>Ground the pump and all other equipment used or located in the pumping area. Grounding reduces the risk of static and electric shock by providing an escape wire for the electrical current due to static build up or in the event of a short circuit. Check your local electrical code for detailed grounding instructions for your area and type of equipment.</p>						

- *Pump:* Connect a ground wire and clamp as shown in FIG. 2. Loosen the grounding screw (W). Insert one end of a 12 ga (1.5 mm²) minimum ground wire (X) behind the grounding screw and tighten the screw securely. Connect the clamp end of the ground wire to a true earth ground. To order a ground wire and clamp, order part number 222011.

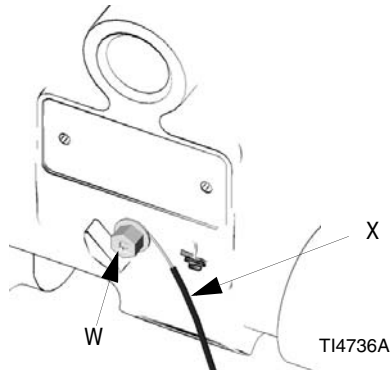

FIG. 2: Ground Wire Connection

- *Air and fluid hoses:* Use only grounded hoses with a maximum of 500 ft (150 m) combined hose length to ensure grounding continuity.
- *Air compressor:* Follow the manufacturer's recommendations.
- *Fluid supply container:* Follow the local code.

Mountings

NOTE: The pump exhaust air may contain contaminants. Ventilate to a remote area if the contaminants could affect your fluid supply. See **Air Exhaust Ventilation** on page 11.

- Be sure the mounting surface can support the weight of the pump, hoses, and accessories, as well as the stress caused during operation.
- For ease of operation and service, mount the pump so the air valve cover, air inlet, and fluid inlet and outlet ports are easily accessible.

Air Line

<p>A bleed-type master air valve (B) is required in the system to relieve air trapped between this valve and the pump. Trapped air can cause the pump to cycle unexpectedly, which could result in serious injury including splashing in the eyes or on the skin, injury from moving parts, or contamination from hazardous fluids. See FIG. 3.</p>						

1. Install the air line accessories as shown in FIG. 3. Mount these accessories on the wall or on a bracket. Be sure the air line supplying the accessories is grounded.

- a. Install an air regulator (C) and gauge to control the fluid pressure. The fluid outlet pressure will be the same as the setting of the air regulator.
- b. Locate one bleed-type master air valve (B) close to the pump and use it to relieve trapped air. Locate the other master air valve (E) upstream from all air line accessories and use it to isolate them during cleaning and repair.
- c. The air line filter (F) removes harmful dirt and moisture from the compressed air supply.

2. Install a grounded, flexible air hose (A) between the accessories and the 1/2 npt(f) pump air inlet (M). Use a minimum 3/8 in. (9.5 mm) ID air hose. Screw an air line quick disconnect coupler (D) onto the end of the air hose (A), and screw the mating fitting into the pump air inlet snugly.

<p>Do not connect the coupler (D) to the fitting until you are ready to operate the pump. Connecting the coupler too early can result in unintentional operation of the pump, leading to serious injury from moving parts, splashing fluid in the eyes or on the skin, and contact with hazardous fluids.</p>						

Fluid Suction Line

1. Use flexible, grounded fluid hoses (G) where possible.
2. For best sealing results, use a standard Tri-Clamp® style sanitary gasket of a flexible material such as EPDM, Buna-N, fluoroelastomer, or silicon.
3. If the fluid inlet pressure to the pump is more than 25% of the outlet working pressure, the ball check valves will not close fast enough, resulting in inefficient pump operation. Excessive inlet fluid pressure also will shorten diaphragm life. Approximately 3-5 psi (0.02-0.03 MPA, 0.21-0.34 bar) should be adequate for most materials.
4. See the **Technical Data** on pages 41 and 44 for maximum suction lift (wet and dry). For best results, always install the pump as close as possible to the material source.

Fluid Outlet Line

--	--	--	--	--	--	--

A fluid drain valve (J) is required to relieve pressure in the hose if it is plugged. The drain valve reduces the risk of serious injury, including splashing in the eyes or on the skin, or contamination from hazardous fluids when relieving pressure. Install the valve close to the pump fluid outlet. See FIG. 3.

1. Use flexible, grounded fluid hoses (L) where possible.
2. For best sealing results, use a standard Tri-Clamp® style sanitary gasket of a flexible material such as EPDM, Buna-N, fluoroelastomer, or silicon
3. Install a fluid drain valve (J) near the fluid outlet. See FIG. 3.
4. Install a shutoff valve (K) in the fluid outlet line.

Typical Installation

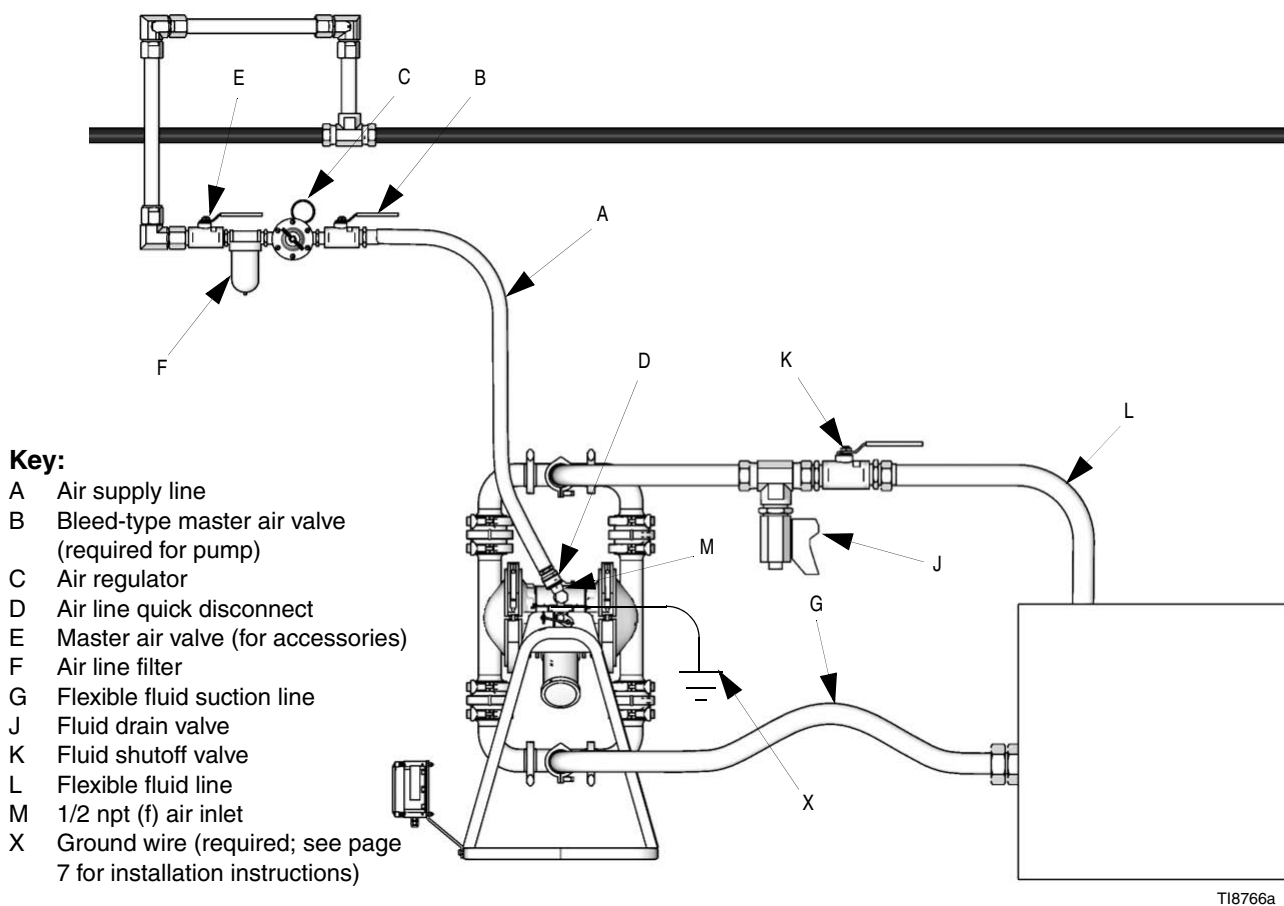

FIG. 3: Typical Floor-Mount Installation

Changing the Orientation of the Fluid Inlet and Outlet Ports

The pump is shipped with the ports facing the same direction. To reorient the ports into any position:

1. Remove the clamps (130) holding the inlet and/or outlet tee to the elbows.
2. Rotate the manifold tee (339) and reattach. Install the clamps (130) and tighten handtight.

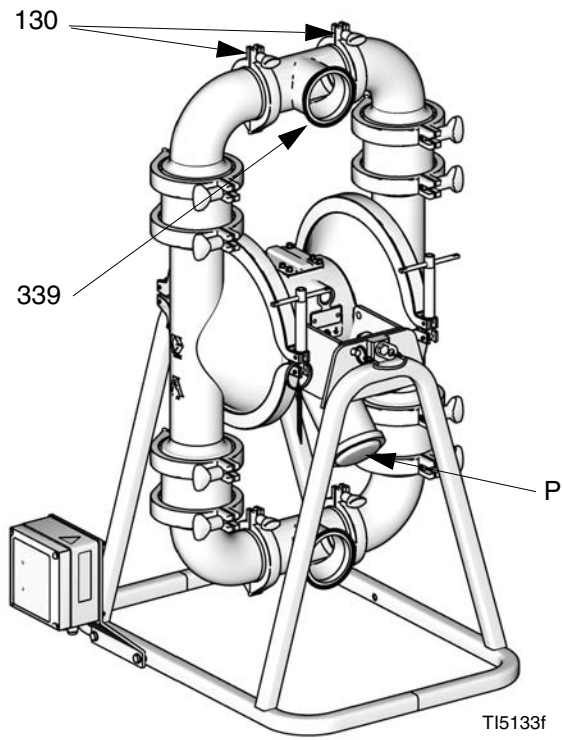
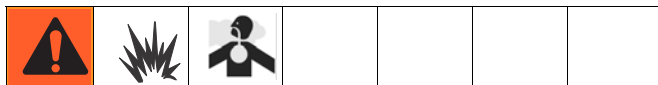

FIG. 4: Orientation of Fluid Ports

Air Exhaust Ventilation



Be sure the system is properly ventilated for your type of installation. You must vent the exhaust to a safe place, away from people, animals, food handling areas, and all sources of ignition when pumping flammable or hazardous fluids.

Diaphragm failure can cause the fluid being pumped to exhaust with the air. Place an appropriate container at the end of the air exhaust line to catch the fluid. See FIG. 5.

The air exhaust port is 3/4 npt(f). Do not restrict the air exhaust port. Excessive exhaust restriction can cause erratic pump operation.

To provide a remote exhaust:

1. Remove the muffler (P) from the pump air exhaust port. See FIG. 5.
2. Install a grounded air exhaust hose (T) and connect the muffler (P) to the other end of the hose. The minimum size for the air exhaust hose is 3/4 in. (19 mm) ID. If a hose longer than 15 ft (4.57 m) is required, use a larger diameter hose. Avoid sharp bends or kinks in the hose.
3. Place a grounded container (U) at the end of the air exhaust line to catch fluid in case of a diaphragm rupture. See FIG. 5.

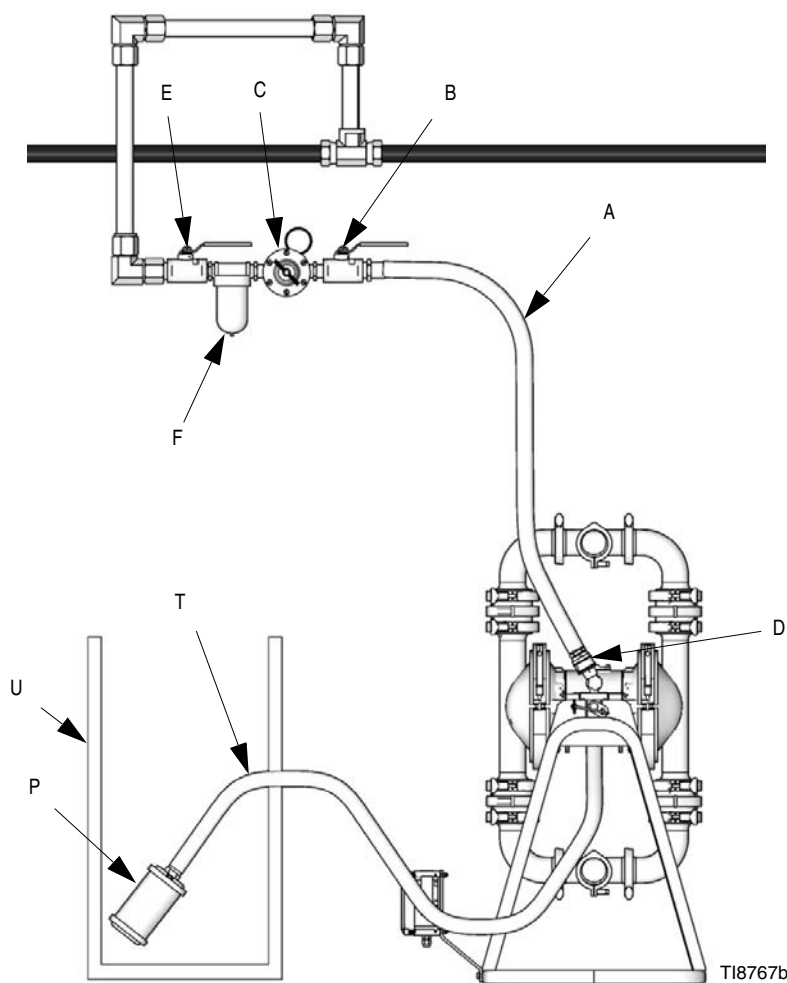

Key:

- A Air supply line
- B Bleed-type master air valve (required for pump)
- C Air regulator
- D Air line quick disconnect
- E Master air valve (for accessories)
- F Air line filter
- P Muffler
- T Grounded air exhaust hose
- U Container for remote air exhaust

FIG. 5: Venting Exhaust Air

Operation

Pressure Relief Procedure



Trapped air can cause the pump to cycle unexpectedly, which could result in serious injury from injection, splashing or moving parts. Relieve pressure when you stop pumping and before cleaning, checking, or servicing equipment.

1. Shut off the air to the pump.
2. Open any available outbound fluid valve to relieve fluid pressure from the pump.
3. If fluid is still in the outbound fluid lines, isolate this fluid as follows:
 - a. Close the outbound fluid valves.
 - b. Slowly remove the fluid connections from the pump, and have a container ready to catch any fluid that runs out.

Sanitizing the Pump Before First Use



NOTE: The pump was built and tested using a food grade lubricant.

It is the user's responsibility to properly sanitize the pump before first use. It is up to the user whether this will include disassembling and cleaning individual parts or simply flushing pump with a sanitizing solution. As necessary, follow the steps under **Starting and Adjusting the Pump** below, under **Flushing** on page 13, or under **Disassembly** in the **Service** section on pages 20, 22, and 25.

Starting and Adjusting the Pump

1. Be sure the pump is properly grounded. See **Grounding**, page 7.
2. Check connections to be sure they are tight. Tighten fluid inlet and outlet connections securely.
3. Place the suction tube (if used) in fluid to be pumped.

NOTE: If fluid inlet pressure to the pump is more than 25% of the outlet working pressure, the ball check valves will not close fast enough, resulting in inefficient pump operation.

4. Place the end of fluid hose (L) into an appropriate container.
5. Close the fluid drain valve (J).
6. Back out the air regulator (C) knob, and open all bleed-type master air valves (B, E).
7. If the fluid hose has a dispensing device, hold it open while continuing with the following step.
8. Slowly increase air pressure with the air regulator (C) until the pump starts to cycle. Do not exceed the maximum operating air pressure as listed in the Technical Data section on pages 41 and 44. Allow the pump to cycle slowly until all air is pushed out of the lines and the pump is primed.

Pump Shutdown



At the end of the work shift, relieve pressure.

Maintenance

Lubrication

The air valve is designed to operate unlubricated. If lubrication is desired, every 500 hours of operation (or monthly) remove the hose from the pump air inlet and add two drops of machine oil to the air inlet.

NOTICE

Do not over-lubricate the pump. Oil is exhausted through the muffler and could contaminate your fluid supply or other equipment. Excessive lubrication can also cause the pump to malfunction.

Flushing



Insert suction tube into cleaning solution. Open air regulator to supply low pressure air to the pump. Run the pump long enough to thoroughly clean the pump and hoses. Close the air regulator. Remove the suction tube from the cleaning solution and drain pump. Place suction tube in the fluid to be pumped.

Flush the pump often enough to prevent the fluid you are pumping from drying or freezing in the pump and damaging it. Flushing schedule will be based on what the pump is being used for. Use a compatible cleaning solution and always cycle the pump during the entire flushing process.

Always flush the pump and relieve the pressure before storing it for any length of time.

Routine Cleaning of Product Contact Section of Pump

NOTE: The pump and the system should be cleaned in accordance with your state sanitary standard codes and local regulations.

1. Flush the system. See **Flushing** above.
2. Follow the **Pressure Relief Procedure**, page 12.
3. Disassemble the fluid section of the pump and accessories. See **Check Valve Repair**, page 20, and **Standard Diaphragm Repair**, page 22, or **3A/Overmolded Diaphragm Repair**, page 25.

4. Using a brush or other C.I.P. methods, wash all product contact pump parts with an alkaline detergent at the manufacturer's recommended temperature and concentration.
5. Rinse these parts again with water and allow parts to completely dry.
6. Inspect the parts and reclean any soiled parts.
7. Immerse all product contact parts in an approved sanitizer before assembly. Leave the parts in the sanitizer, taking them out only one by one as needed for assembly. See **Check Valve Repair**, page 20, and **Standard Diaphragm Repair**, page 22, or **3A/Overmolded Diaphragm Repair**, page 25.
8. Lubricate the clamps, clamping surfaces, and gaskets with waterproof sanitary lubricant.
9. Circulate the sanitizing solution through the pump and the system prior to use. Cycle the pump as the sanitizing solution is circulated.

Tightening Connections

Before each use, check all hoses for wear or damage, and replace as necessary. Check to be sure all connections are tight and leak-free.

Preventive Maintenance Schedule

Establish a preventive maintenance schedule based on the pump's service history. This is especially important for prevention of spills or leakage due to diaphragm failure.

The following is a list of recommended maintenance procedures and frequencies. Maintenance must be performed by trained personnel per the established schedule.

Task	Operator	Maintenance Person	
	Daily	Weekly	Monthly
Inspect system for leaks	✓		
Depressurize fluid, after operation	✓		
Remove heat from system, after operation	✓		
Inspect diaphragm for wear	✓		
Inspect check valve components for wear	✓		
Check hoses for wear		✓	
Check/tighten fluid connections		✓	
Check/tighten air connections		✓	
Lubricate air valves			✓

Troubleshooting



- Follow the **Pressure Relief Procedure**, page 12, before checking or servicing the equipment.
- Check all possible problems and causes before disassembling the pump.

PROBLEM	CAUSE	SOLUTION
Pump cycles at stall or fails to hold pressure at stall.	Worn check valve balls (541) or seats (233).	Replace. See page 20.
Pump will not cycle, or cycles once and stops.	Air valve is stuck or dirty.	Disassemble and clean air valve. See page 17. Use filtered air.
	Check valve ball (541) severely worn and wedged in seat (233) or manifold.	Replace ball and seat. See page 20.
	Check valve ball (541) is wedged into seat (233), due to overpressurization.	Follow Pressure Relief Procedure , page 12. Disassemble ball check assembly and inspect for damage, see page 20.
	Dispensing valve clogged.	Relieve pressure and clear valve.
	Leak detector has activated a shutdown solenoid	Investigate failure and reset leak detector
Pump operates erratically.	Clogged suction line.	Inspect; clear.
	Sticky or leaking balls (541).	Clean or replace. See page 20.
	Diaphragm ruptured.	Replace. See page 22 (standard) or page 25 (3A/Overmolded).
	Restricted exhaust.	Remove restriction.
Air bubbles in fluid.	Suction line is loose.	Tighten.
	Diaphragm ruptured.	Replace. See page 22 (standard) or page 25 (3A/Overmolded).
	Loose inlet manifold, damaged seal between manifold and seat, damaged gaskets.	Tighten manifold clamps or replace seats or gaskets. See page 20.

PROBLEM	CAUSE	SOLUTION
Leak in inlet or outlet sanitary fitting.	Loose sanitary clamp.	Tighten clamp.
	Damaged or worn gasket.	Replace gasket.
	Misalignment of inlet/outlet hose or pipe.	Use flexible hoses at pump inlet and outlet.
	Gasket does not seal.	Use a standard sanitary gasket of flexible material such as EPDM, Buna-N, fluoroelastomer, or silicon.
Fluid in exhaust air.	Diaphragm ruptured.	Replace. See page 22 (standard) or page 25 (3A/Overmolded).
	Loose diaphragm plate.	Tighten or replace. See page 22 (standard) or page 25 (3A/Overmolded).
Pump exhausts excessive air at stall.	Worn air valve block, plate, pilot block, u-cups, or pilot pin o-rings.	Repair or replace. See page 17.
	Worn shaft seals.	Replace. See page 22 (standard) or page 25 (3A/Overmolded).
Pump leaks air externally.	Air valve cover is loose.	Tighten screws. See page 17.
	Air valve gasket or air cover gasket is damaged.	Inspect; replace. See page 17.
	Air cover clamps are loose	Tighten clamps.
Pump leaks fluid externally from ball check valves.	Loose manifolds, damaged seal between manifold and seat, damaged gaskets.	Tighten manifold clamps or replace seats or clamps (132). See page 20.
Chattering.	Check balls not seating properly/cleanly due to imbalance between fluid inlet and outlet line sizing. Noise is accentuated with light viscosity fluids.	Reduce size/diameter of inlet line relative to outlet line. Outlet line size should not exceed pump size.

Service

Repairing the Air Valve

Tool Required

- Torque wrench
- Torx (T20) screwdriver or 7 mm (9/32 in.) socket wrench
- Needle-nose pliers
- O-ring pick
- Lithium base grease

Air Valve Repair Kit 255122 is available. Refer to **Parts** on page 35. Parts included in the kit are marked with ♦ symbol. Use all the parts in the kit for the best results.

Disassembly



1. Follow the **Pressure Relief Procedure**, page 12.
2. With a Torx (T20) screwdriver or 7 mm (9/32 in.) socket wrench, remove the six screws (103), air valve cover (102), and gasket (104). See FIG. 6.

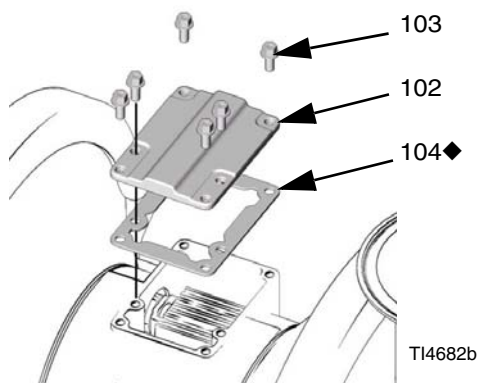

FIG. 6

3. Move the valve carriage (105) to the center position and pull it out of the cavity. Using a needle-nose pliers, pull the pilot block (116) straight up and out of the cavity. See FIG. 7.

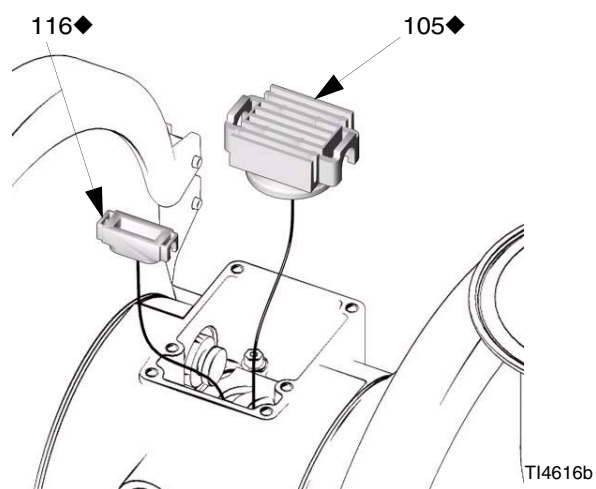

FIG. 7

4. Pull the two actuator pistons (111). Remove the u-cups (110) from the pistons. Pull the pilot pins (114). Remove the o-rings (115) from the pilot pins. See FIG. 8.

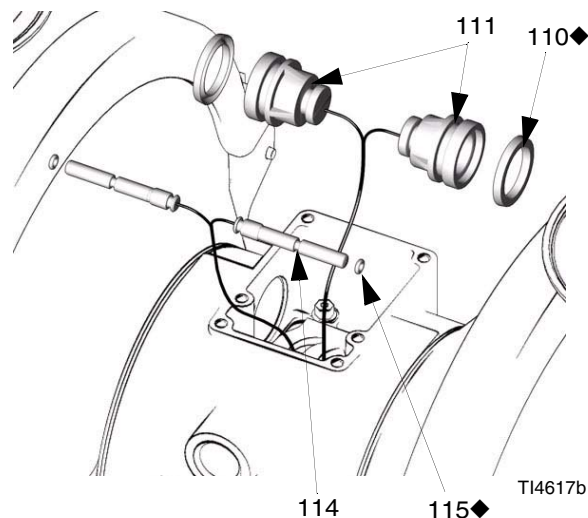

FIG. 8

5. Inspect the valve plate (108) in place. If damaged, use a Torx (T20) screwdriver or 7 mm (9/32 in.) socket wrench to remove the three screws (103). Remove the valve plate (108). See FIG. 9.

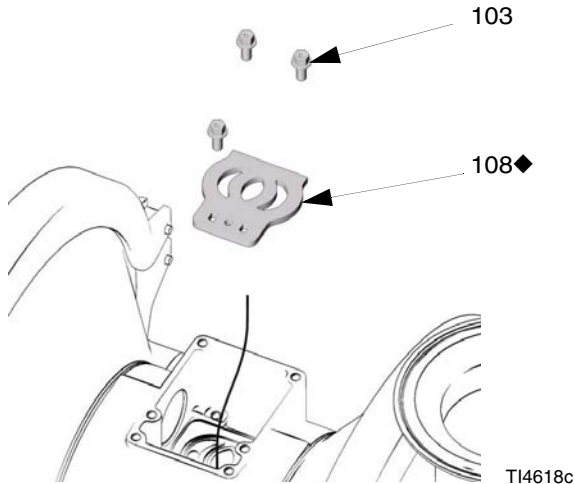

FIG. 9

6. Inspect the bearings (112, 117) in place. See **Parts** on page 35. The bearings are tapered and, if damaged, must be removed from the outside. This requires disassembly of the fluid section. See page 27.
7. Clean all parts and inspect for wear or damage. Replace as needed. Reassemble, page 18.

Reassembly

1. If you replaced the bearings (112, 117), reinstall as explained on page 27. Reassemble the fluid section.
2. Install the valve plate (108) in the cavity, seal down. Install the three screws (103), using a Torx (T20) screwdriver or 7 mm (9/32 in.) socket wrench. Tighten until the screws bottom out on the housing. See FIG. 9.
3. Install an o-ring (115) on each pilot pin (114). Grease the pins and o-rings. Insert the pins into the bearings, **narrow** end first. See FIG. 10.

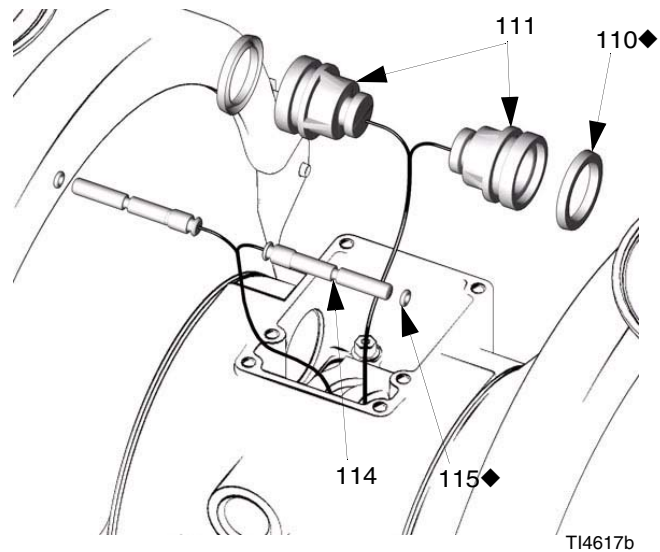

FIG. 10

4. Install u-cups (110) on each actuator piston (111), so the lips of the packings face the **narrow** end of the pistons. See FIG. 10.
5. Lubricate the u-cups (110) and actuator pistons (111). Insert the actuator pistons in the bearings, **wide** end first. Leave the narrow end of the pistons exposed. See FIG. 10.

6. Grease the lower face of the pilot block (116) and install so its tabs snap into the grooves on the ends of the pilot pins (114). See FIG. 11.
7. Grease the lower face of the valve carriage (105). See FIG. 11.
8. Install the valve carriage (105) so its tabs slip into the grooves on the narrow end of the actuator pistons (111). See FIG. 11.

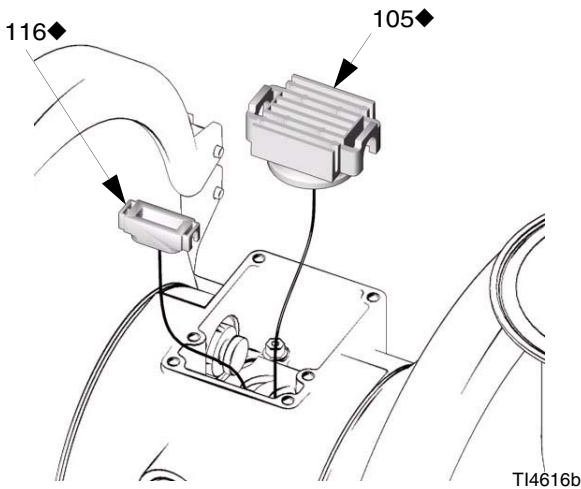

FIG. 11

9. Align the valve gasket (104) and cover (102) with the six holes in the center housing (101). Secure with six screws (103), using a Torx (T20) screwdriver or 7 mm (9/32 in.) socket wrench. Torque to 50-60 in-lb (5.7-6.8 N•m). See FIG. 12.

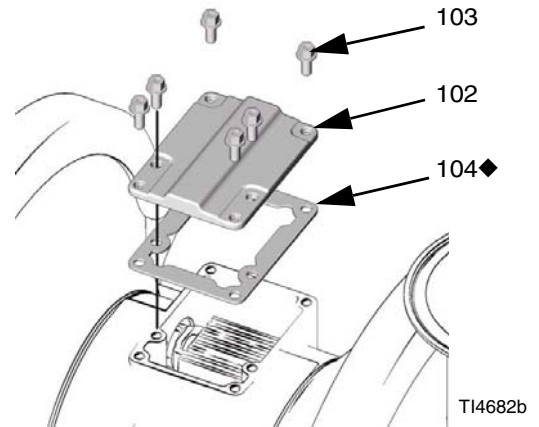

FIG. 12

Check Valve Repair

Disassembly

Reference numbers with an asterisk (*) are replacement parts. For a complete list of replacement parts see **Parts**, page 30 and following.



1. Follow the **Pressure Relief Procedure**, page 12. Disconnect all hoses.
2. Pull the quick release pins and tilt the pump to drain.
3. From the outlet manifold, remove both upper clamps (132a).
4. Remove outlet manifold leaving elbows (128), gaskets (129), clamps (130), and tee (339) assembled.
5. *For 3A Ball Check pumps:* remove ball gasket (240). Remove middle clamp (132c) and ball stop housing (2XA). Remove middle gasket (240) and ball (541). Remove lower clamp (132b), seat (2XB), and gasket (240). Clean all parts and inspect for wear or damage. Replace parts as needed.

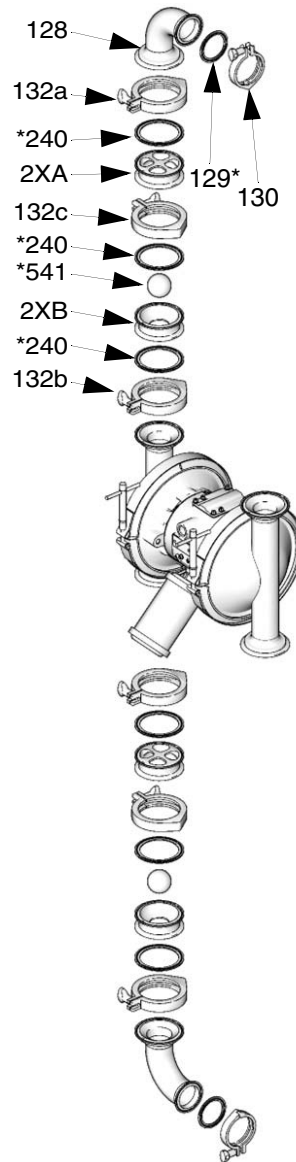

T18768a

FIG. 13: 3A Ball Check Assembly

For Sanitary Ball Check pumps: remove ball gasket (242) and ball (541). Remove lower clamp (132b), seat (233), and gasket (240). Clean all parts and inspect for wear or damage. Replace parts as needed.

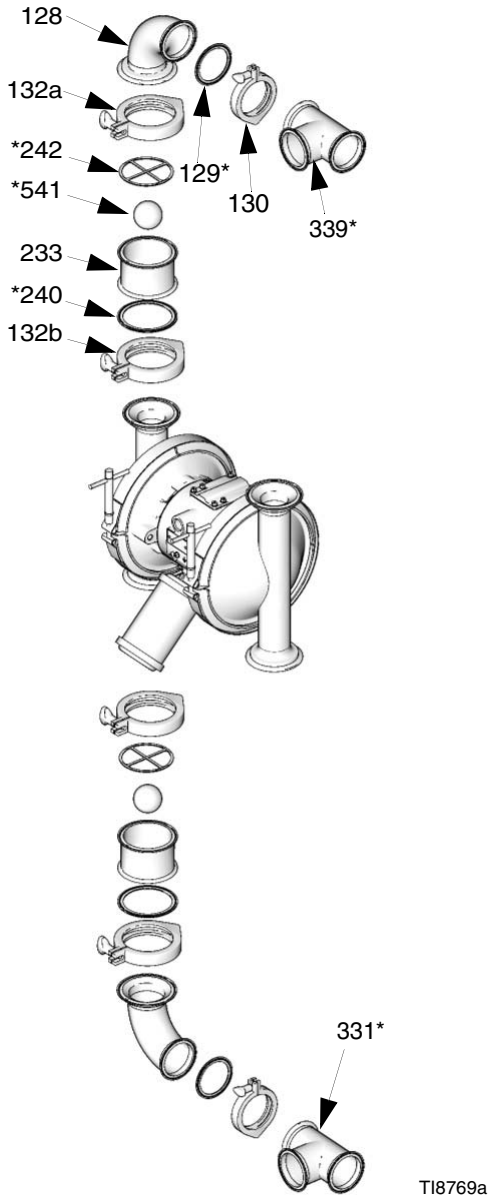

FIG. 14: Sanitary Ball Check Assembly

For Flapper Check pumps: remove gasket (240). Remove middle clamp (132c) and housing (252). Remove middle gasket (240), and flapper valve (251). Remove lower clamp (132b), lower flapper housing (248), and gasket (240). Clean all parts and inspect for wear or damage. Replace parts as needed.

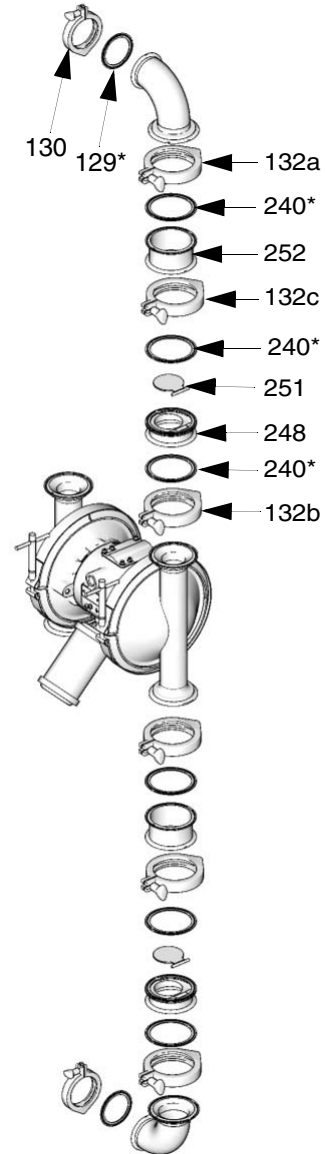

FIG. 15: Flapper Check Assembly

- Disassemble the outlet manifold. Remove clamps (130), tee (339), gasket (129), and elbow (128). Clean all parts and inspect for wear or damage. Replace parts as needed.
- Repeat for inlet manifold.

Reassembly

NOTE: Lubricate clamps, clamping surfaces, and gaskets with waterproof, sanitary lubricant.

- Reassemble inlet and outlet fluid manifolds in reverse order. See step 6. Tighten clamps hand-tight.
- Reassemble ball or flapper check assembly in reverse order. See step 5. Tighten clamps hand-tight.

NOTE: For flapper check, make sure flapper check (251) is placed properly in housing (248) groove. Ensure that the flapper check moves freely.

Standard Diaphragm Repair

NOTE: See page 25 for overmolded diaphragms, including all 3A diaphragms.

Tools Required

- Torque wrench
- 5/8 in. wrench
- 19 mm open end wrench
- O-ring pick
- Lithium-base grease
- Spanner wrench

Disassembly

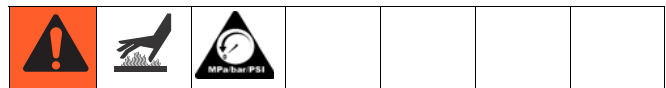

- Follow the **Pressure Relief Procedure**, page 12.
- Remove the manifolds and disassemble the ball check valves as explained on page 20.
- Hold fluid covers in place and remove the clamps (135). Pull the fluid covers (234) off the pump.

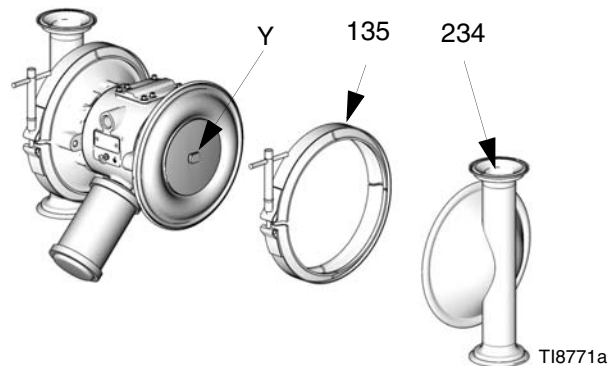

FIG. 16

4. With both fluid covers removed, using two 5/8 in. wrenches hold the wrench flats (Y) on the plates of each diaphragm assembly and loosen. One diaphragm assembly will come free and the other will remain attached to the shaft.
5. Disassemble the free diaphragm assembly.
6. Remove plate (444) with bolt (143) installed, diaphragm (446), backer (447) if present, and plate (445).
8. Inspect the diaphragm shaft (121) for wear or scratches. If it is damaged, inspect the bearings (117) in place. If the bearings are damaged, refer to **Bearing and Air Gasket Removal** on page 27.
9. Reach into the center housing (101) with an o-ring pick and hook the u-cups (110), then pull them out of the housing. This can be done with the bearings (117) in place. See FIG. 24, page 27.
10. Clean all parts and inspect for wear or damage. Replace parts as needed.

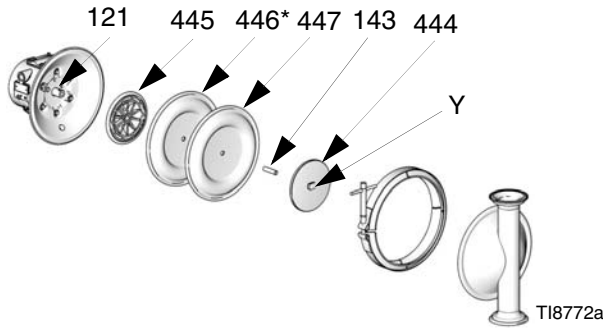

FIG. 17

7. Pull the other diaphragm assembly and the diaphragm shaft (121) out of the center housing (101). Hold the shaft flats with a 19 mm open end wrench, and remove the diaphragm assembly from the shaft. Disassemble the remaining diaphragm assembly.

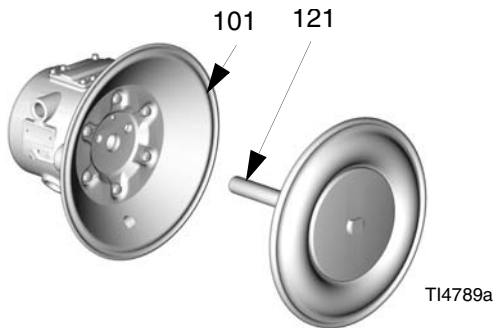
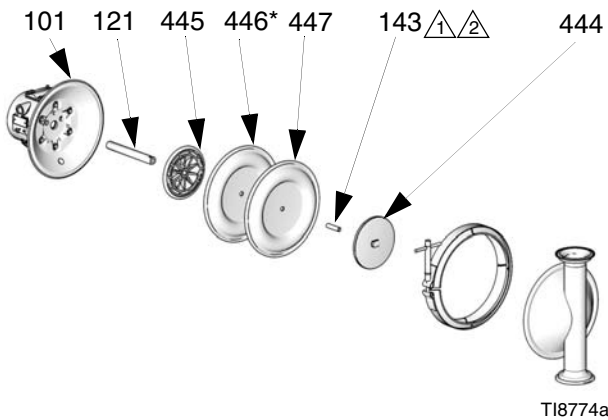

FIG. 18

Reassembly

1. Install the shaft u-cups (110) so the lips face **out** of the housing (101). Lubricate the u-cups. See **Reassembly of Bearing**, page 27.
2. Assemble diaphragm (446), backer (447) if present, and plate (445) onto plate (444) with screw (143). Rounded side of plate (445) should face diaphragm. Make sure the side marked AIR SIDE faces the center housing.

NOTE: Thread locker must be applied to screw (143) as shown in FIG. 19 for all diaphragm assemblies.



- △1 Apply a high-strength thread locker to attach the screw to the diaphragm plate, if needed.
- △2 Apply a medium-strength thread locker to the shaft side of the screw.

FIG. 19

3. Screw assembled diaphragm assembly into shaft (121) and hand tighten.
4. Grease the length of the diaphragm shaft (121), and slide it through the housing (101).
5. Assemble the other diaphragm assembly to the shaft as explained in step 2.
6. Using a 5/8 in. wrench hold the wrench flats of one diaphragm assembly and torque the other diaphragm to 60-70 ft-lb (81-94 N•m).

NOTE: Waterproof, sanitary lubricant may be applied to the clamp (135) and clamping surface of the cover (234) to ease assembly.

7. Align the fluid covers (234) and the center housing. Secure the covers with the clamps (135) and hand tighten.

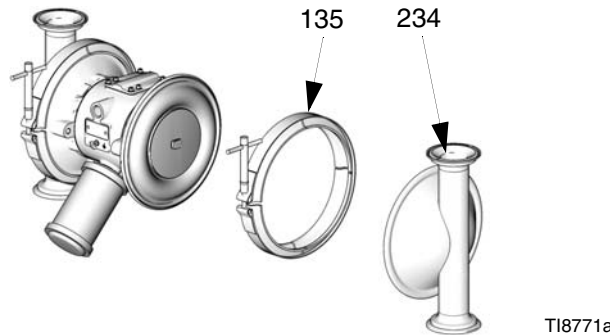

FIG. 20

8. Reassemble the ball check valves and manifolds as explained on page 20.

3A/Overmolded Diaphragm Repair

NOTE: If your pump uses standard diaphragms, see page 22.

Tools Required

- Torque wrench
- 19 mm open end wrench
- O-ring pick
- Lithium-base grease

Disassembly



1. Follow the **Pressure Relief Procedure**, page 12.
2. Remove the manifolds and disassemble the ball check valves as explained on page 20.
3. Remove the clamps (135) holding the fluid covers (234) to the air covers (120). Pull the fluid covers (234) off the pump. See FIG. 21.
4. Once the fluid covers are removed, the diaphragm on the side of the pump which was last pressurized with air will be separated from the center section/air cover. This allows you to grip the diaphragms.
5. Diaphragms are assembled handtight. To loosen, grip both diaphragms securely around the outer edge and rotate counterclockwise. One diaphragm assembly will come free and the other will remain attached to the shaft. Remove the freed diaphragm (446) and air side plate (445).
6. Pull the opposite diaphragm assembly and shaft (121) out of the center housing (101). Hold the shaft flats with a 19 mm open end wrench and remove the diaphragm and air side plate from the shaft.
7. Inspect the diaphragm shaft (121) for wear or scratches. If it is damaged, inspect the bearings (117) in place. If the bearings are damaged, refer to page 27.
8. Reach into the center housing (101) with an o-ring pick and hook the u-cup packings (110), then pull them out of the housing. This can be done with the bearings (117) in place.
9. Clean all parts and inspect for wear or damage. Replace parts as needed.

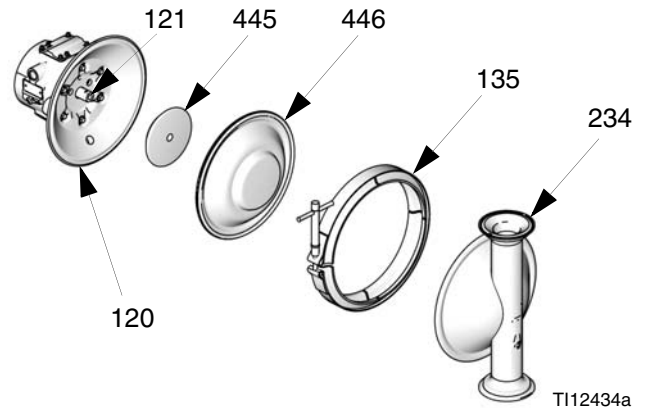



FIG. 21

Reassembly

						
<p>To reduce the risk of serious injury, including amputation, do not put your fingers or hand between the air cover and the diaphragm.</p>						

1. Install the shaft u-cup packings (110*) so the lips face **out** of the housing (101). Lubricate the packings. See FIG. 24, page 27.
2. Apply high-strength (red) Loctite® or equivalent to attach the bolt (446a) to the diaphragm (446), if needed. Assemble the air side plate (445) onto the diaphragm (446). The wide, radiused side of the plate must face the diaphragm. Apply medium-strength (blue) Loctite® or equivalent to the threads of the diaphragm assembly. Screw the assembly into the shaft (121) hand tight.
3. Grease the length and ends of the diaphragm shaft (121). Insert the shaft/diaphragm assembly into one side of the pump.

NOTE: Turn the pump 90° on the stand for easier fluid cover clamping.

Align the fluid cover (234) and the center housing. Securely tighten the clamp (135).

4. Assemble the other diaphragm assembly to the shaft as explained in step 2. This diaphragm will be lifted off the air cover at this point.
5. Supply the pump with low pressure air (less than 7 psi [.05 MPa, 0.5 bar]). The diaphragm will very slowly pull onto the air cover (120). Find the pressure that keeps the diaphragm close enough to clamp, but does not let it contact the pilot pin.

NOTICE
<p>Do not deform the diaphragm manually. The diaphragm needs uniform pressure to deform properly.</p>

6. Assemble the fluid cover (234) and clamp (135) so the cover is aligned to the center housing. Tilt pump for easier assembly. Securely tighten the clamp.

NOTE: If the diaphragm contacts the pilot pin and is forced away from the air cover, try Step 5 again. If necessary, return to Step 3.

7. Reassemble the ball check valves and manifolds as explained on page 20.

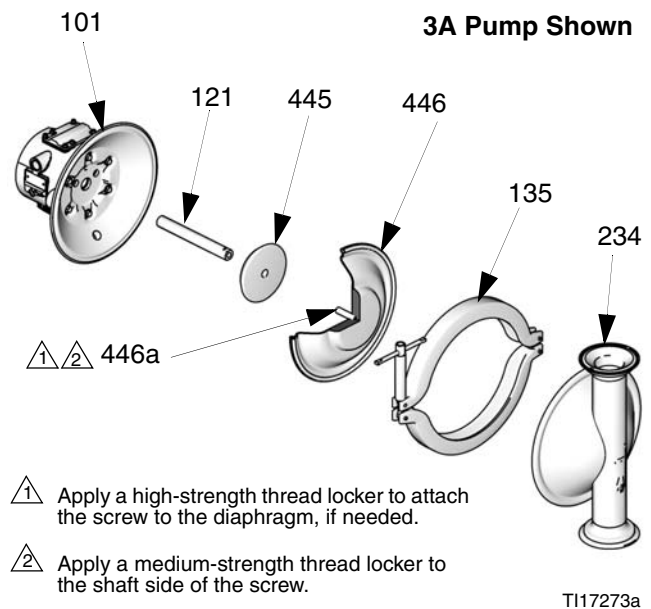

FIG. 22

Bearing and Air Gasket Removal

Tools Required

- Torque wrench
- 10 mm socket wrench
- Bearing puller
- O-ring pick
- Press, or block and mallet

Disassembly

NOTE: Do not remove undamaged bearings.



1. Follow the **Pressure Relief Procedure**, page 12.
2. Remove the manifolds and disassemble the ball check valves as explained on page 20.
3. Remove the fluid covers and diaphragm assemblies as explained on page 22 (standard) or page 25 (3A/Overmolded).

NOTE: If you are removing only the diaphragm shaft bearing (117), skip step 4.

4. Disassemble the air valve as explained on page 17.
5. Using a 10 mm socket wrench, remove the screws (122) holding the air covers (120) to the center housing (101).

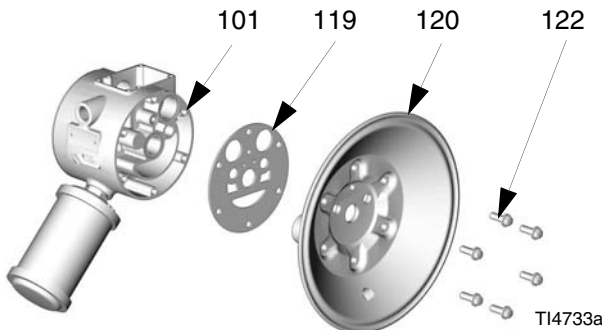

FIG. 23

6. Remove the air cover gaskets (119). Always replace the gaskets with new ones.
7. Use a bearing puller to remove the diaphragm shaft bearings (117), air valve bearings (112) or pilot pin bearings (113). Do not remove undamaged bearings

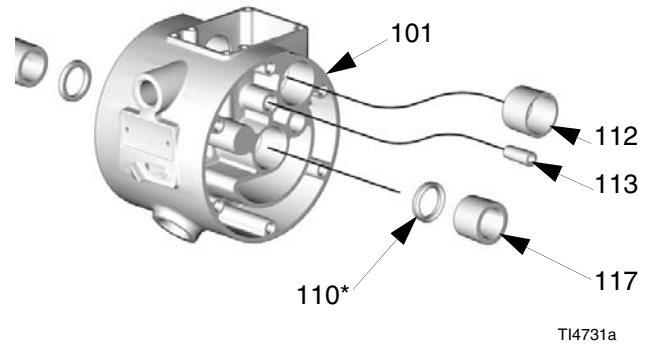

FIG. 24

8. If you removed the diaphragm shaft bearings (117) reach into the center housing (101) with an o-ring pick and hook the u-cups (110), then pull them out of the housing. Inspect the u-cups. See FIG. 24. Replace parts as needed.

Reassembly

NOTE: Adhesive must be applied to the outside surface of the bearing (112) and the inside surface of bore (Z) prior to assembly.

1. Install the shaft u-cups (110) so the lips face **out** of the housing.
2. Insert new bearings (112, 113, and 117) into the center housing (101), **tapered end first**. Using a press or a block and rubber mallet, press-fit the bearing so it is flush with the surface of the center housing.

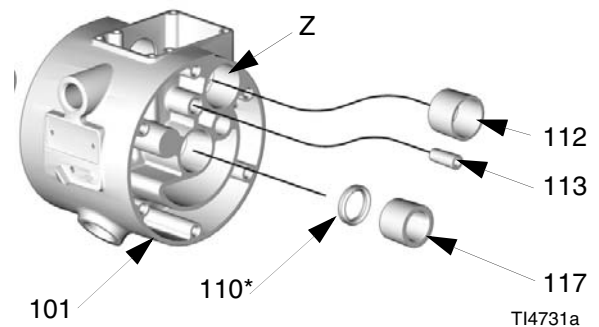

FIG. 25

3. Reassemble the air valve as explained on page 17.

- Align the new air cover gasket (119) so the pilot pin (114) protruding from the center housing (101) fits through the proper hole in the gasket

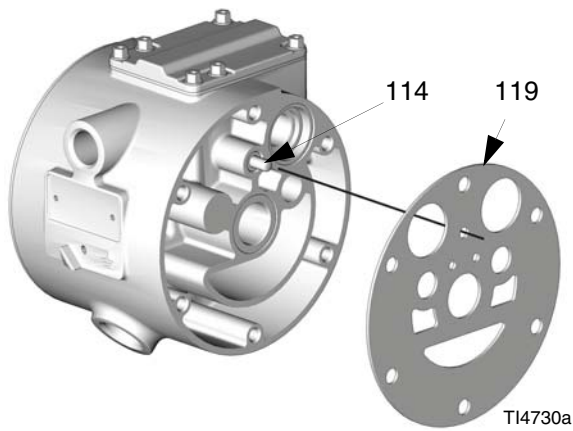

FIG. 26

- Align the air cover (120) so the pilot pin (114) fits in the middle hole (M) of the three small holes near the center of the cover.

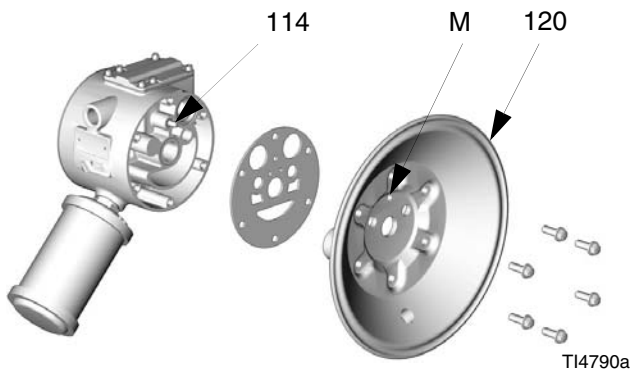

FIG. 27

- Apply medium-strength (blue) Loctite® or equivalent to the threads of the screws (122). Install the screws (122), handtight. Using a 10 mm socket wrench, torque the screws oppositely and evenly to 130-150 in-lb (15-17 N•m). Install the diaphragm assemblies and fluid covers as explained on page 22.



FIG. 28

- Reassemble the ball check valves and manifolds as explained on page 20.

Pump Matrix

NOTE: For BES/Ram Models (Non-Matrix Part Numbers 24xxxx), see page 36.

SaniForce 3150 Stainless Steel Sanitary Pumps

Your Model No. is marked on the pump's serial plate. To determine the Model No. of your pump from the following matrix, select the six digits which describe your pump, working from left to right. The first digit is always **S**, designating Graco Sanitary diaphragm pumps. The remaining five digits define the pump configuration, size, and materials of construction. For example, a sanitary

ball check pump with a three inch inlet and outlet, Santoprene balls and diaphragms, a pump stand, and no leak detector is model **SB3661**. To order replacement parts, refer to the part lists on pages 30 - 35. *The digits in the matrix **do not** correspond to the reference numbers in the parts drawing and lists.*

Sanitary Pump	Pump Configuration	Inlet and Outlet (in.)	Diaphragm	Check Ball Material	Leak Detector, Pump Stand
S - (for all pumps)	A 3A Approved Ball Check (HD)	1 1 1/2 x 1 1/2	A 3A Approved (EPDM)	A 3A Approved (PTFE)	A Leak Detector and Pump Stand
	B Ball Check	2 2 x 2	3 (HD) PTFE/EPDM overmolded	6 Santoprene®	1 Pump Stand
	F Flapper Check	3 3 x 3	6 Santoprene®	7 Buna-N	3 None
		4 4 x 4	7 Buna-N	8 fluoroelastomer	
		5 3 x 2	8 fluoroelastomer	F Flapper	
		P NONE			

SaniForce 1590 Stainless Steel Sanitary Pumps

The table below shows all available configurations for 1590 Stainless Steel Sanitary Pumps.

Model Number	Pump Configuration	Inlet and Outlet (in.)	Check Valve Style	Check Ball Material	Diaphragm Material
SABAAA	3A Approved with Leak Detector	2 x 2	3A Ball Checks (HD)	3A PTFE	3A Approved EPDM
SBBAAA	Non-3A Approved No Leak Detector	2 x 2	3A Ball Checks (HD)	3A PTFE	3A Approved EPDM
SBBA11	Non-3A Approved No Leak Detector	2 x 2	3A Ball Checks (HD)	3A PTFE	PTFE
SBBA22	Non-3A Approved No Leak Detector	2 x 2	3A Ball Checks (HD)	Santoprene	Santoprene
SABA13	Non-3A Approved with Leak Detector	2 x 2	3A Ball Checks (HD)	3A PTFE	PTFE/EPDM overmolded (HD)
SBBA13	Non-3A Approved No Leak Detector	2 x 2	3A Ball Checks (HD)	3A PTFE	PTFE/EPDM overmolded (HD)

Parts Drawing, Fluid Section

3A Pump Shown

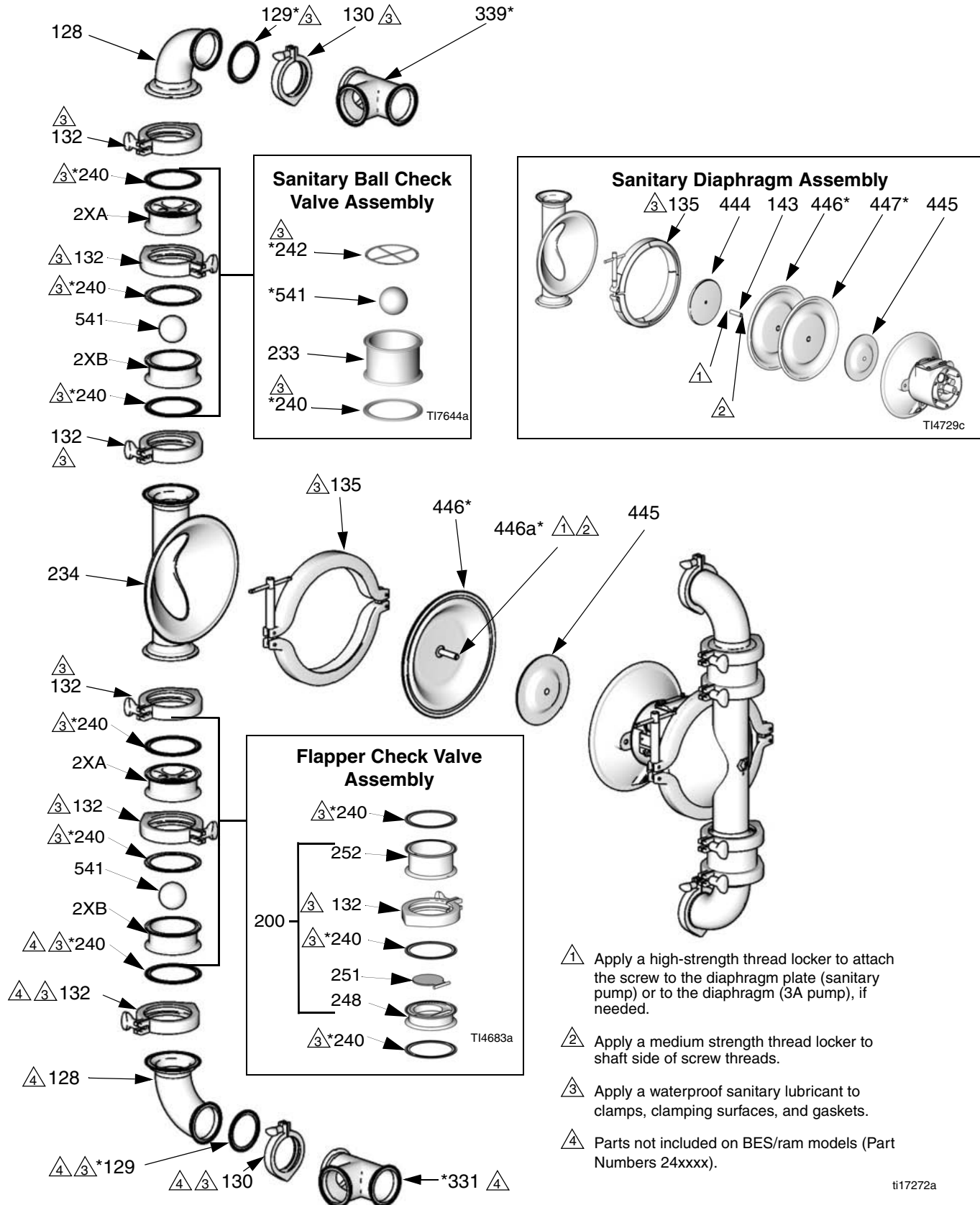

- 1 Apply a high-strength thread locker to attach the screw to the diaphragm plate (sanitary pump) or to the diaphragm (3A pump), if needed.
- 2 Apply a medium strength thread locker to shaft side of screw threads.
- 3 Apply a waterproof sanitary lubricant to clamps, clamping surfaces, and gaskets.
- 4 Parts not included on BES/ram models (Part Numbers 24xxxx).

ti17272a

Parts List, Fluid Section

Pump Configuration

Digit	Ref. No.	Part No.	Description	Qty
Model 3150				
A	3A Approved Ball Check Pump			
	132	510490	CLAMP, 4 in.	4
	2XB	15H406	SEAT	4
	234	249533	COVER, fluid	2
	240*	15H460	GASKET, 4 in., EPDM	12
	2XA	15H407	STOP, ball	4
B	Standard Ball Check Pump			
	233	15D026	SEAT	4
	234	234530	COVER, fluid	2
	240*	15H460	GASKET, 4 in., EPDM	4
	242*	15D346	GASKET, ball stop	4
F	Flapper Check Pump			
	234	234530	COVER, fluid	2
	240*	15H460	GASKET, 4 in., EPDM	12
	200	16E975	MODULE, flapper; includes 4x of items 132, 248, 251, 252, and 12x item 240	1
	132	510490	CLAMP, 4 in.	4
	248	16D853	HOUSING, lower flapper	4
	251	16D854	VALVE, flapper, weldment	4
	252	15D090	HOUSING, upper flapper	4
Model 1590				
All	132	15D475	CLAMP, 3 in.	4
All	2XB	15H481	SEAT	4
All	234	249892	COVER, Fluid	2
All	240*	15H459	GASKET, 3 in., EPDM	12
All	2XA	15H482	STOP, Ball	4
A	3A Approved Ball Check Pump			
	135	24J608	CLAMP, sanitary, diaphragm	2
B	Standard Ball Check Pump			
	135	15H341	CLAMP, sanitary, diaphragm	2

* Indicates replacement parts.

Inlet and Outlet

Digit	Ref. No.	Part No.	Description	Qty
Model 3150				
1	1 1/2 x 1 1/2 in. tee			
	331*	234536	TEE, inlet	1
	339*	234536	TEE, outlet	1
2	2 x 2 in. tee			
	331*	234534	TEE, inlet	1
	339*	234534	TEE, outlet	1
3	3 x 3 in. tee			
	331*	234532	TEE, inlet	1
	339*	234532	TEE, outlet	1
4	4 x 4 in. tee			
	331*	234535	TEE, inlet	1
	339*	234535	TEE, outlet	1
5	3 x 2 in. tee			
	331*	234532	TEE, inlet	1
	339*	234534	TEE, outlet	1
Model 1590				
2 x 2 in. Tee				
All	331*	249893	TEE, Inlet	1
All	339*	249893	TEE, Outlet	1

* Indicates replacement parts.

Digit	Ref.	Part	Description	Qty.
Model 3150				
All	128	234531	ELBOW	4
	129	15H459	GASKET, sanitary, EPDM, 3 in.	4
	130	15D475	CLAMP, sanitary, 3 in.	4
	132	510490	CLAMP, sanitary, 4 in.	8
	135	15G323	CLAMP, sanitary, diaphragm	2
Model 1590				
All	128	249894	ELBOW	4
	129	15H598	GASKET, sanitary, EPDM, 2 in.	4
	130	500984	CLAMP, sanitary, 2 in.	4
	132	15D475	CLAMP, sanitary, 3 in.	8

Diaphragm Material

Digit	Ref.	Part	Description	Qty
Model 3150				
A	253224 3A Approved, EPDM, Overmolded; includes 110 and 446			
	110	112181	U-CUP	2
	446*†		DIAPHRAGM ASSY	2
	445	189298	PLATE, diaphragm (air side)	2
3	253628 (HD) PTFE; includes 110, 446			
	110	112181	U-CUP	2
	446*†		DIAPHRAGM ASSY	2
	445	15H811	PLATE, diaphragm (air side)	2
6	253225 Santoprene; includes 110, 446			
	110	112181	U-CUP	2
	446*†		DIAPHRAGM	2
	143	15D021	BOLT	2
	444	15D018	PLATE, diaphragm	2
	445	189298	PLATE, diaphragm	2
7	253223 Buna-N; includes 110, 446			
	110	112181	U-CUP	2
	446*†		DIAPHRAGM	2
	143	15D021	BOLT	2
	444	15D018	PLATE, diaphragm	2
	445	189298	PLATE, diaphragm	2
8	253222 fluoroelastomer; includes 110, 446			
	110	112181	U-CUP	2
	446*†		DIAPHRAGM	2
	143	15D021	BOLT	2
	444	15D018	PLATE, diaphragm	2
	445	189298	PLATE, diaphragm	2

Model	Ref.	Part	Description	Qty
Model 1590				
255058 3A Approved, EPDM, Overmolded; includes 110 and 446				
SABAAA SBBAAA	110	112181	U-CUP	2
	446*†		DIAPHRAGM ASSEMBLY	2
	445	15K448	PLATE, Diaphragm (air side)	
255059 Santoprene; includes 110 and 446				
SBBA22	110	112181	U-CUP	2
	446*†		DIAPHRAGM	2
	143	15D021	BOLT	2
	444	15K288	PLATE, Diaphragm (fluid side)	2
	445	15K448	PLATE, Diaphragm (air side)	2
255060 PTFE; includes 110 and 446 and 447				
SBBA11	110	112181	U-CUP	2
	446*†		DIAPHRAGM	2
	447*†		BACKER	2
	143	15D021	BOLT	2
	444	15K288	PLATE, Diaphragm (fluid side)	2
	445	15K448	PLATE, Diaphragm (air side)	2
253627 (HD) PTFE; includes 110, 446				
SABA13 SBA13	110	112181	U-CUP	2
	446*†		DIAPHRAGM ASSY	2
	445	15H810	PLATE, diaphragm (air side)	2

All diaphragm modules above include 2 u-cups (110) to replace seals around shaft (121). See page 34.

* Indicates replacement parts.

† Indicates a recommended spare part.

Check Ball Material

Digit	Ref.	Part	Description	Qty
Model 3150				
A	3A Approved, PTFE			
	541*†	112359	BALL	4
F	Flapper check			
		NONE		
6	Santoprene			
	541*†	112361	BALL	4
7	BUNA-N			
	541*†	15B492	BALL	4
8	fluoroelastomer			
	541*†	15B491	BALL	4
Model 1590				
	3A Approved PTFE			
SABAAA SBBAAA SBBA11	541*†	112419	BALL	4
	Santoprene			
SBBA22	541*†	112421	BALL	4

* Indicates replacement parts.

† Indicates a recommended spare part.

Parts Drawing, Air Section and Stand

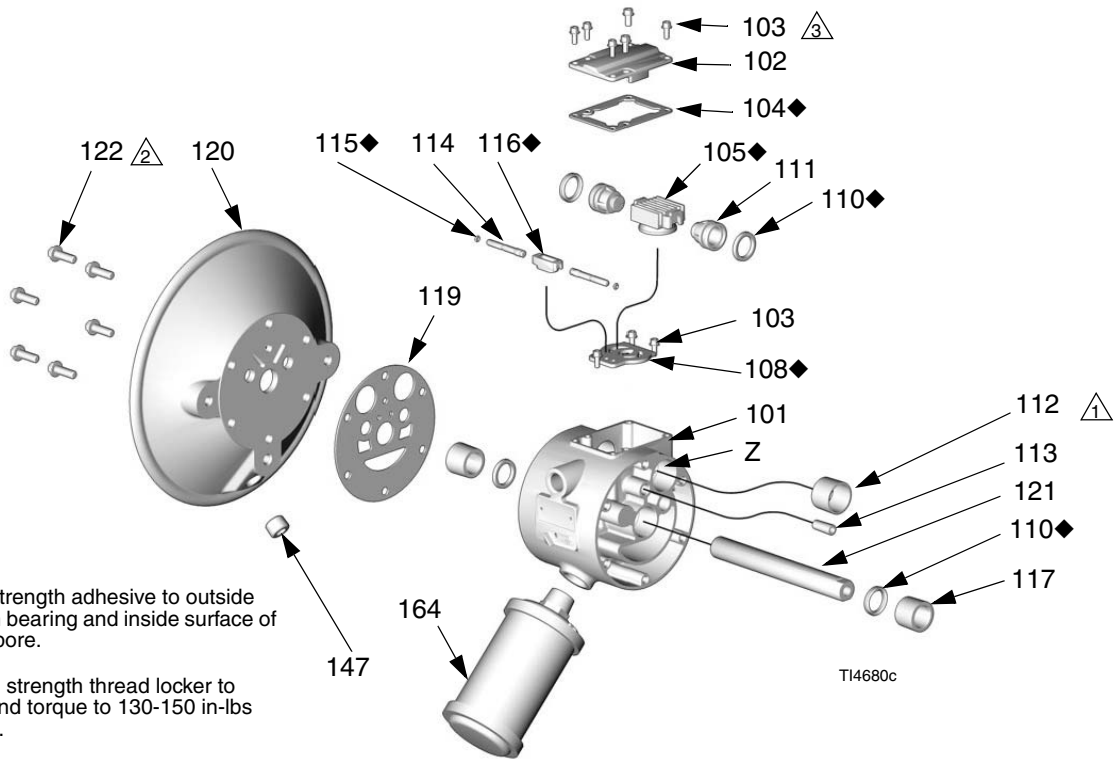

⚠️ Apply medium strength adhesive to outside surface of piston bearing and inside surface of center housing bore.

⚠️ Apply a medium strength thread locker to screw threads and torque to 130-150 in-lbs (14.6-16.9 N•m).

⚠️ Torque to 50-60 in-lb (5.7-6.8 N•m).

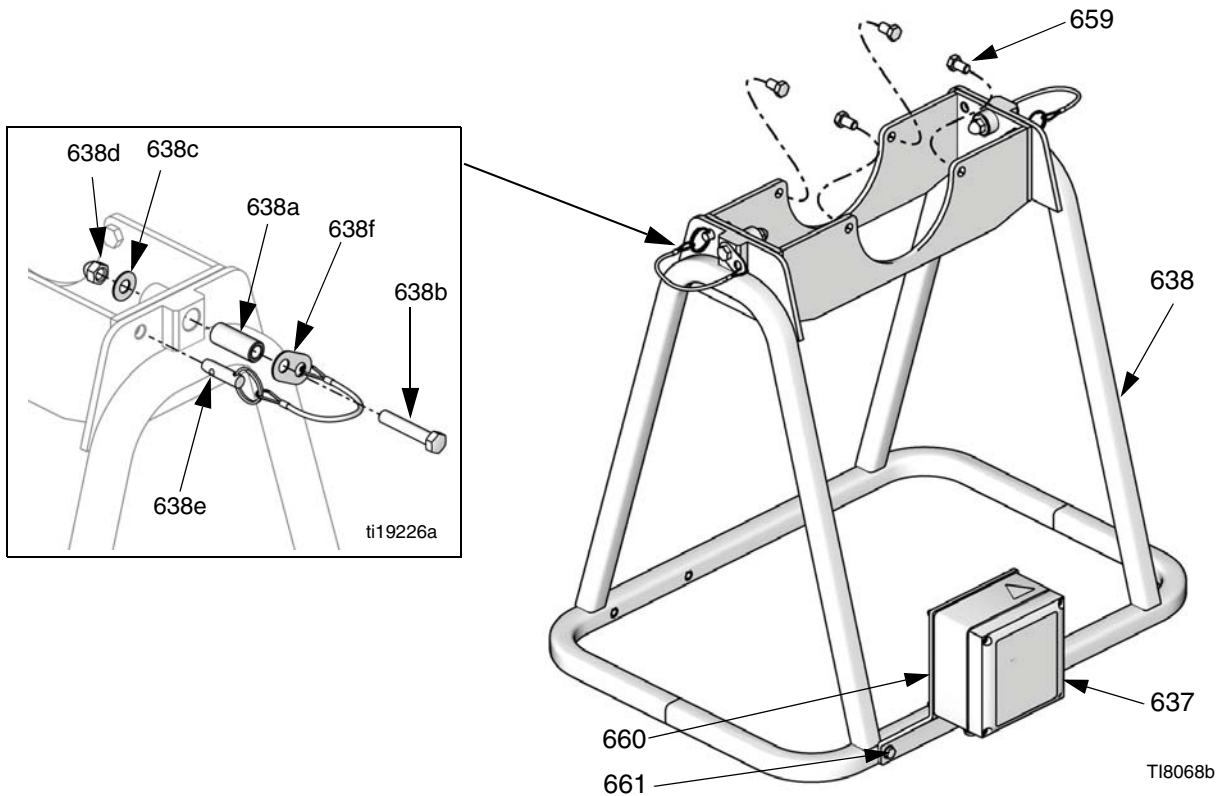

Parts List, Air Section and Stand

Air Section - All Models

Digit	Ref.	Part	Description	Qty.
ALL Models	101	15K010	HOUSING, center	1
	102	15K697	HOUSING, cover	1
	103	116344	SCREW, mach, torx	10
	104◆	188618	GASKET, cover	1
	105◆	248904	CARRIAGE, manifold assy	1
	108◆	15H178	VALVE, plate	1
	110◆	112181	U-CUP, packing	4
	111	188612	PISTON, actuator	2
	112	188613	BEARING, piston	2
	113	188611	BEARING, pin	2
	114	188610	PIN, push	2
	115◆	157628	O-RING	2
	116◆	188614	BLOCK, pilot	1
	117	188609	BEARING, shaft	2
	119	188603	GASKET air cover	2
	120	15D016	COVER, machined air, 3150	2
		15G694	COVER, machined air, 1590	2
	121	189245	SHAFT	1
	122	112178	SCREW	12
	147	103778	PLUG	2
162▲	188621	TAG, warning	1	
164	15G332	MUFFLER	1	

◆ Parts included in Air Valve Repair Kit 255122 (purchase separately).

▲ Replacement Danger and Warning labels, tags, and cards are available at no cost.

Leak Detector and Pump Stand

Digit	Ref.	Part	Description	Qty
A	3A Approved, Leak Detector and Pump Stand 3150 and 1590 SABAAA			
	637	15D990	LEAK DETECTOR	1
	638	24L978	FRAME (includes 4 bolts, ref. 659)	1
	659	15D008	BOLT, sst	4
	660	15H971	GASKET, upper	1
	661	15H972	GASKET, lower	1
1	Pump Stand Only 3150 and 1590 SBBAAA, SBBA11, SBBA22			
	638	24L978	FRAME (includes 4 bolts, ref. 659)	1
	659	15D008	BOLT, sst	4
3	Bare Pump			
			none	

* Indicates replacement parts.

† Indicates a recommended spare part.

Kit 24N798 Hinge Repair Kit

Ref.	Description	Qty.
638a	BUSHING	2
638b	BOLT	2
638c	WASHER	2
638d	NUT, acorn	2

Kit 24N799 Quick-Release Pin Repair Kit

Ref.	Description	Qty.
638e	LOCK PIN, with lanyard	2
638f	RETAINER	2

Parts List, Models 248273, 248274, 24C124, 24E440, 24E667, 24J388, and 24J389

NOTE: These 3150 models are for use with ram systems or Bin Evacuation Systems and do not include a fluid inlet tee, elbows, and related parts.

Fluid Section Parts

(see **Parts Drawing, Fluid Section** on page 30)

Ref.	Part	Description	Qty.
128	234531	ELBOW	2
129	15H459	GASKET, sanitary, EPDM, 3 in.	2
130	15D475	CLAMP, sanitary, 3 in.	2
132	510490	CLAMP, sanitary, 4 in.	8
135	15G323	CLAMP, sanitary, diaphragm	2
143	15D021	BOLT	2
339*	234532	TEE, outlet; 3 x 3 in.	1
444	See Table	PLATE, diaphragm	2
445	See Table	PLATE, diaphragm	2
446*†	See Table	DIAPHRAGM	2

Ball Check Parts

(Models 248273, 24C124, 24E440, 24E667, 24J388, and 24J389)

Ref.	Part	Description	Qty.
233	See Table	SEAT	4
234	234530	COVER, fluid	2
240*	15H460	GASKET, 4 in., EPDM	2 or 3
242*	See Table	BALL STOP/GASKET	4
2XA	See Table	BALL STOP	4
541*†	See Table	BALL	4

Flapper Check Parts

(Model 248274 only)

Ref.	Part	Description	Qty.
234	234530	COVER, fluid	2
240*	15H460	GASKET, 4 in., EPDM	10
200	16E975	MODULE, flapper; includes 4x of items 132, 248, 251, 252, and 12x item 240	1
132	510490	. CLAMP, 4 in.	4
248	16D853	. HOUSING, lower flapper	4
251	16D854	. VALVE, flapper, weldment	4
252	15D090	. HOUSING, upper flapper	4

* Indicates replacement parts.

† Indicates a recommended spare part.

Air Section Parts

(see **Parts Drawing, Air Section and Stand** on page 34)

Ref.	Part	Description	Qty.
101	15K010	HOUSING, center	1
102	15K697	HOUSING, cover	1
103	116344	SCREW, mach, torx	10
104◆	188618	GASKET, cover	1
105◆	248904	CARRIAGE, manifold assy	1
108◆	15H178	VALVE, plate	1
110◆	112181	U-CUP, packing	4
111	188612	PISTON, actuator	2
112	188613	BEARING, piston	2
113	188611	BEARING, pin	2
114	188610	PIN, push	2
115◆	157628	O-RING	2
116◆	188614	BLOCK, pilot	1
117	188609	BEARING, shaft	2
119	188603	GASKET air cover	2
120	15D016	COVER, machined air, 3150	2
121	189304	SHAFT	1
122	112178	SCREW	12
147	103778	PLUG	2
162▲	188621	TAG, warning	1

◆ Parts included in Air Valve Repair Kit 255122 (purchase separately).

▲ Replacement Danger and Warning labels, tags, and cards are available at no cost.

Parts that Vary by Model

Ref.	Description	Qty	248273	248274	24C124	24E440	24E667	24J388	24J389
2XB	SEAT	4			15H406	15H406		15H406	15H406
2XA	BALL STOP	4			15H407	15H407		15H407	15H407
233	SEAT	4	15D026				15D026		
242	BALL STOP/GASKET	4	15D346				15D346		
444	PLATE diaphragm, fluid side	2	15D018	15D018				15D018	
445	PLATE, diaphragm, air side	2	189289	189289	189298	189298	15H811	189298	15H811
446	DIAPHRAGM	2							
	Santoprene, includes 2 u-cups (110)		253225	253225				253225	
	EPDM Overmolded				15F914	15F914			
	PTFE/EPDM Overmolded						15G746		15G746
541	BALL	4							
	PTFE				112359	112359			112359
	Santoprene		112361				112361	112361	

Accessories

15D990 Leak Detector

Sensor and control package that monitors the diaphragm condition. In case of diaphragm failure, the control will provide an audible alarm and relay contacts for remote alarms or solenoids. See Leak Detector manual 311200.

NOTE: To be  approved, a leak detection system must be used on the pump. Any pump with a leak detector installed is NOT ATEX approved.

NOTE: To replace a sensor, order Part No. 24B290 Leak Detector Sensor Replacement Kit. The kit includes one sensor.

3150 Conversion Kits

15H461 3A Approved Ball Check Conversion Kit

Converts flapper check valve to 3A ball check valve. Includes four seats and four ball stops. Balls need to be ordered separately.

Part No.	Description	Qty.
15B406	SEAT, ball	4
15H460	GASKET, 4 in.	12
510490	CLAMP, 4 in.	4
15H407	STOP, ball	4

16E975 Flapper Valve Conversion Kit

Converts ball check valve to flapper check valve. Includes four flapper assemblies. See **Flapper Valve Assembly**, page 30.

Part No.	Description	Qty.
15H460	GASKET, 4 in., EPDM	12
15D090	HOUSING, upper flapper	4
16D853	HOUSING, lower flapper	4
16D854	VALVE, flapper, weldment	4
510490	CLAMP, 4 in.	4

15E285 Sanitary Ball Check Conversion Kit

Converts flapper check valve to sanitary ball check valve. Includes four seats and four ball stops. Balls need to be ordered separately.

Part No.	Description	Qty.
15D026	SEAT, ball	4
15D346	GASKET, ball stop	4

Model 1590 Dimensional Drawing

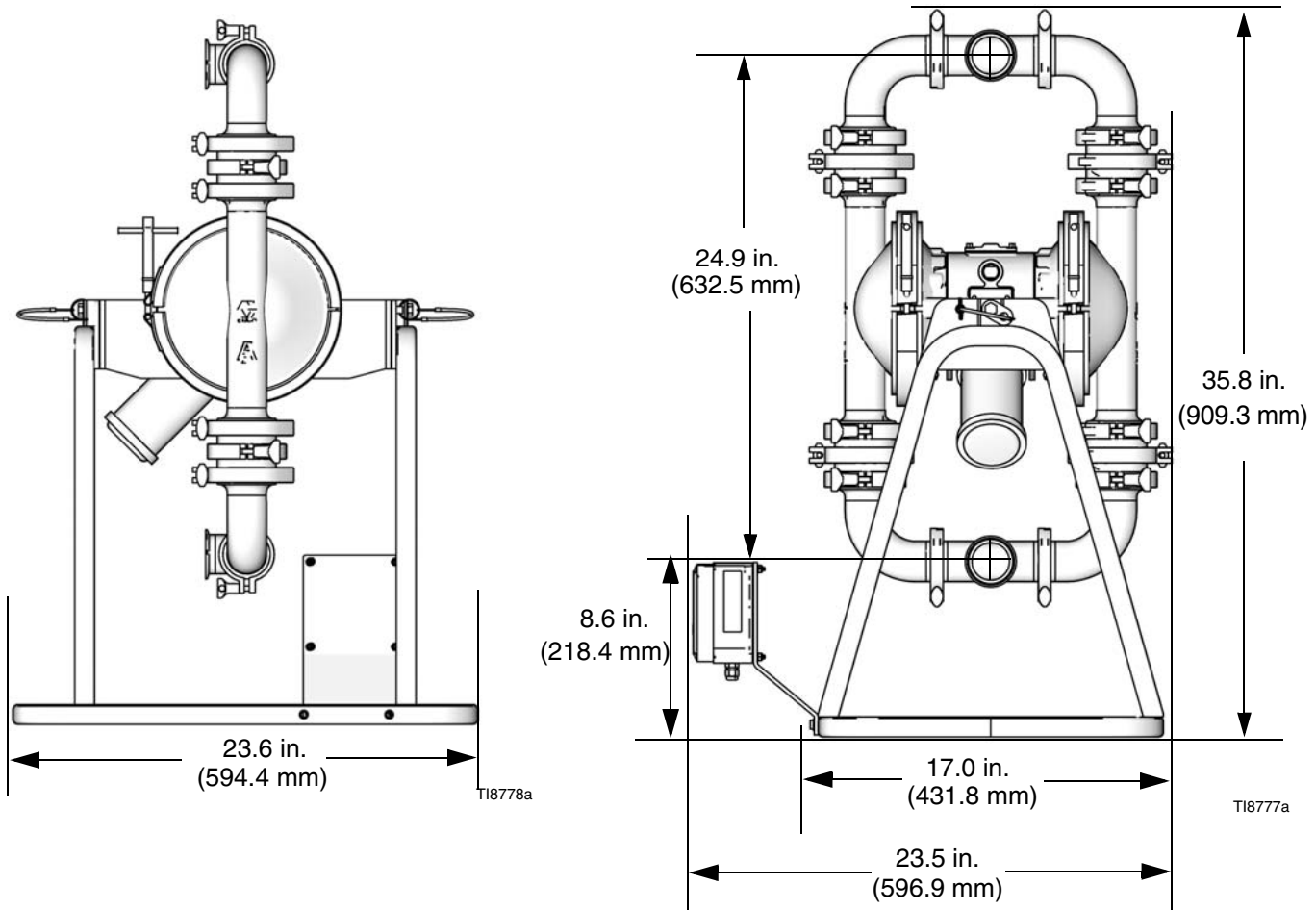

Model 1590 Technical Data

Maximum fluid working pressure	120 psi (0.8 MPa, 8 bar)
Air pressure operating range	20-120 psi (0.14-0.8 MPa, 1.4-8 bar)
Maximum air consumption	125 scfm
Air consumption at 70 psi air inlet pressure/60 gpm.	50 scfm (see chart)
Maximum free-flow delivery	100 gpm (378.5 l/min)
Maximum pump speed	200 cpm
* Gallons (Liters) per cycle	0.5 (1.96)
Maximum suction lift (varies widely based on ball/seat selection and wear, operating speed, material properties, and other variables)	28 ft (8.5 m) wet, 15 ft (4.57 m) dry
Maximum size pumpable solids	5/8 in. (15.9 mm)
** Maximum Noise Level at 100 psi, full flow	90 dBa
** Sound Power Level	103 dBa
** Noise Level at 70 psi and 50 cpm.	85 dBa

Maximum fluid operating temperature is based on the following maximum diaphragm, ball, and seat temperature ratings.

PTFE balls; PTFE/EPDM 2-piece diaphragm	220°F (104.4°C)
PTFE /EPDM Overmolded (HD) diaphragm.	180°F (82.2°C)
Santoprene balls or diaphragm	180°F (82.2°C)
3A Approved EPDM Overmolded diaphragm.	275°F (135°C)

Air inlet size 0.5 in. npt(f)

Wetted parts

***All fluid contact materials are FDA-compliant and meet the United States Code of Federal Regulations (CFR) Title 21, Section 177.

All fluid contact materials are FDA-compliant.

Wetted materials on all models.	316 SST, 3A Approved EPDM, PTFE,
Wetted material depending on model.	Santoprene®, 3A Approved EPDM, PTFE

CAUTION:

Santoprene® may be used only with non-fatty, non-oily foods or alcohols up to 15%.

Non-wetted external parts. 300 series stainless steel, polyester (labels), LDPE foam (gasket)

Weight 97 lb (44 kg)

Santoprene® is a registered trademark of the Monsanto Co.

Loctite® is a registered trademark of the Loctite Corporation.

* *Displacement per cycle may vary based on suction condition, discharge head, air pressure, and fluid type.*

** *Noise levels measured with the pump mounted on the stand. Sound power measured per ISO Standard 9614-1.*

*** *The pump user must verify that the construction materials meet their specific application requirements.*

Model 1590 Performance Chart

Test Conditions: Pump tested in water with inlet submerged

To find Fluid Outlet Pressure

(psi/MPa/bar) at a specific fluid flow (gpm/lpm) and operating air pressure (psi/MPa/bar):

1. Locate fluid flow rate along bottom of chart.
2. Follow vertical line up to intersection with selected fluid outlet pressure curve.
3. Follow left to scale to read fluid outlet pressure.

To find Pump Air Pressure

(scfm or m³/min) at a specific fluid flow (gpm/lpm) and operating air pressure (psi/MPa/bar):

1. Locate fluid flow rate along bottom of chart.
2. Read vertical line up to intersection with selected air consumption curve.
3. Follow left to scale to read fluid outlet pressure.

1590 3A Performance Chart

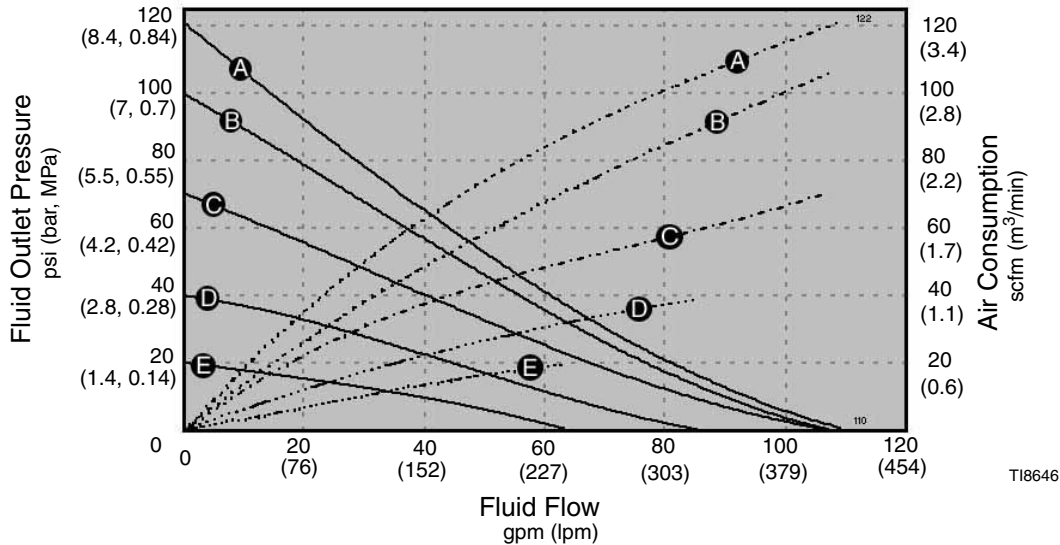

AIR PRESSURES	LEGEND
(A) = @ 120 psi (8.4 bar, 0.84 MPa)	Air Consumption - - - - -
(B) = @ 100 psi (7.0 bar, 0.7 MPa)	Fluid Flow _____
(C) = @ 70 psi (4.8 bar, 0.5 MPa)	
(D) = @ 40 psi (2.8 bar, 0.3 MPa)	
(E) = @ 20 psi (1.4 bar, 0.14 MPa)	

T18647

Model 3150 Dimensional Drawing

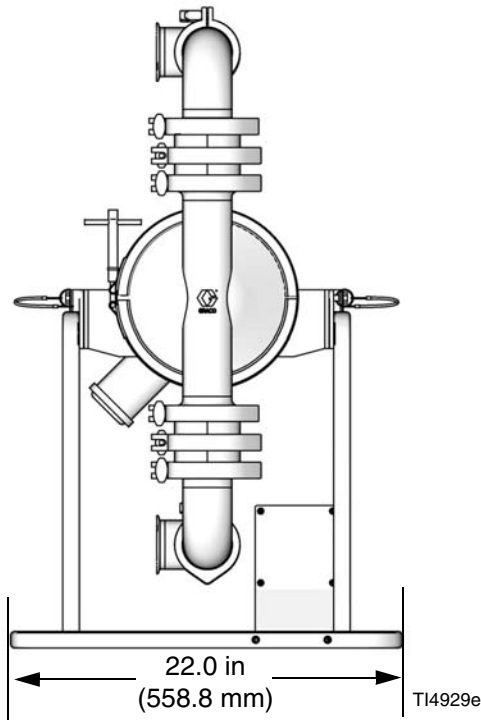

3A Ball Check Valve Pumps

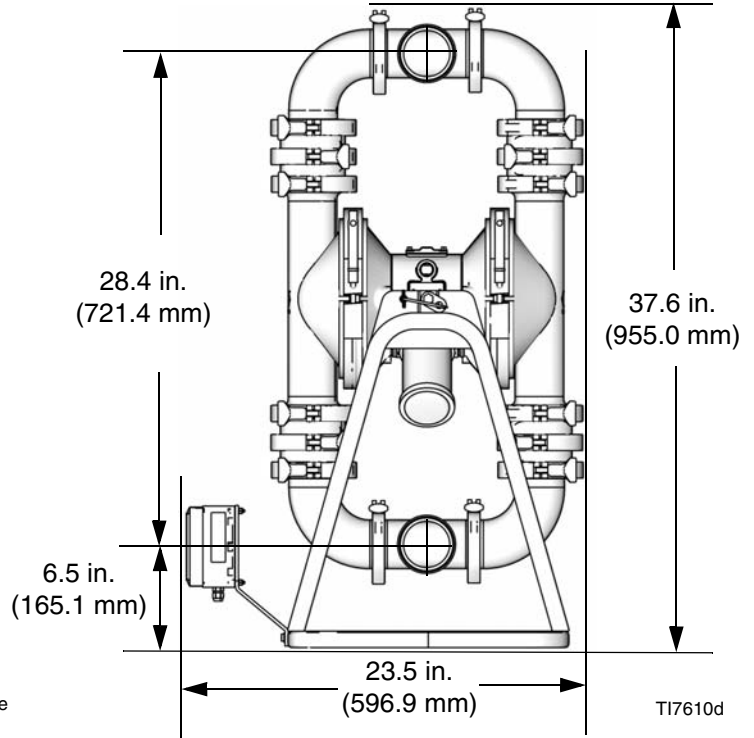

Sanitary Ball Check Valve Pumps

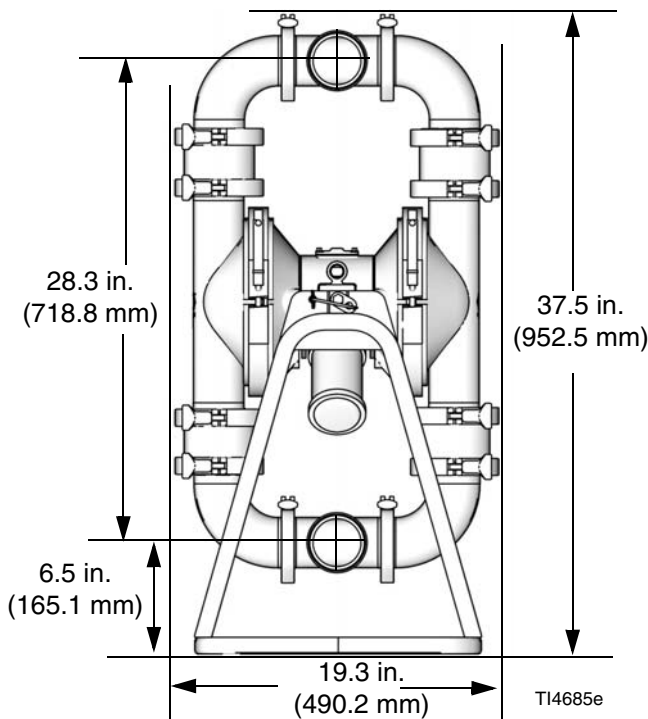

Flapper Check Valve Pumps

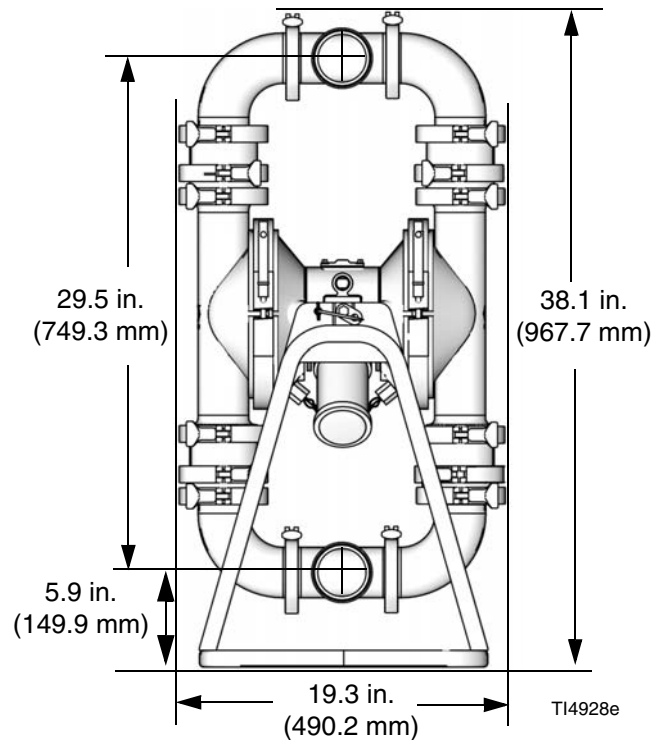

Model 3150 Technical Data

Maximum fluid working pressure	120 psi (0.8 MPa, 8 bar)
Air pressure operating range	20-120 psi (0.14-0.8 MPa, 1.4-8 bar)
Maximum air consumption	175 scfm
Air consumption at 70 psi air inlet pressure/60 gpm.	50 scfm (see chart)
Maximum free-flow delivery	150 gpm (570 l/min)
Maximum pump speed	145 cpm
* Gallons (Liters) per cycle	1.03 (3.90)
Maximum suction lift (varies widely based on ball/seat selection and wear, operating speed, material properties, and other variables)	Flapper 10 ft (3.5 m) wet, 5 ft (1.75 m) dry Ball 18 ft (5.5 m) wet, 9 ft (2.75 m) dry
Maximum size pumpable solids	Flapper 2.5 in. (63.5 mm) Ball 1.0 in. (25.4 mm)
** Maximum Noise Level at 100 psi, full flow	90 dBa
** Sound Power Level	103 dBa
** Noise Level at 70 psi and 50 cpm.	85 dBa

Maximum fluid operating temperature is based on the following maximum diaphragm, ball, and seat temperature ratings.

PTFE balls	220°F (104.4°C)
PTFE/EPDM Overmolded (HD) diaphragm	180°F (82.2°C)
Santoprene balls or diaphragm	180°F (82.2°C)
3A Approved EPDM Overmolded diaphragm	275°F (135°C)
Buna-N balls or diaphragm	180°F (82.2°C)
Fluoroelastomer balls or diaphragm.	250°F (121.1°C)

Air inlet size 0.5 in. npt(f)

Wetted parts

***All fluid contact materials are FDA-compliant and meet the United States Code of Federal Regulations (CFR) Title 21, Section 177.

Wetted materials on all models	316 SST, 3A Approved EPDM
Wetted material depending on model.	316 SST, Santoprene®, Buna-N (Nitrile), fluoroelastomer, 3A Approved EPDM, PTFE

CAUTION:

Santoprene® may be used only with non-fatty, non-oily foods or alcohols up to 15%.

Non-wetted external parts 300 series stainless steel, polyester (labels), LDPE foam (gasket)

Weight 145 lb (66 kg)

Santoprene® is a registered trademark of the Monsanto Co.

Loctite® is a registered trademark of the Loctite Corporation.

* *Displacement per cycle may vary based on suction condition, discharge head, air pressure, and fluid type.*

** *Noise levels measured with the pump mounted on the stand. Sound power measured per ISO Standard 9614-1.*

*** *The pump user must verify that the construction materials meet their specific application requirements.*

Model 3150 Performance Chart

Test Conditions: Pump tested in water with inlet submerged

To find Fluid Outlet Pressure

(psi/MPa/bar) at a specific fluid flow (gpm/lpm) and operating air pressure (psi/MPa/bar):

1. Locate fluid flow rate along bottom of chart.
2. Follow vertical line up to intersection with selected fluid outlet pressure curve.
3. Follow left to scale to read fluid outlet pressure.

To find Pump Air Pressure

(scfm or m³/min) at a specific fluid flow (gpm/lpm) and operating air pressure (psi/MPa/bar):

1. Locate fluid flow rate along bottom of chart.
2. Read vertical line up to intersection with selected air consumption curve.
3. Follow left to scale to read fluid outlet pressure.

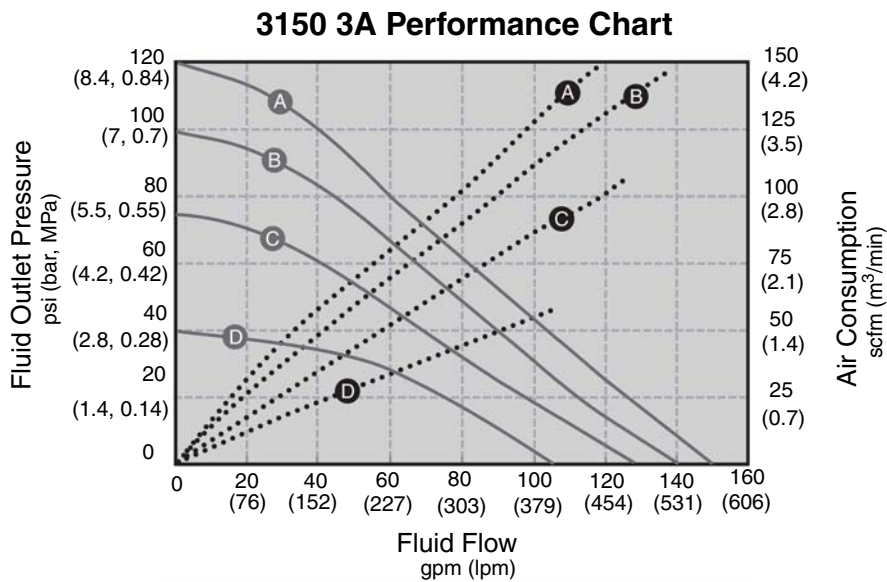

TI8644a

AIR PRESSURES	LEGEND
(A) = @ 120 psi (8.4 bar, 0.84 MPa)	Air Consumption
(B) = @ 100 psi (7.0 bar, 0.7 MPa)	Fluid Flow _____
(C) = @ 70 psi (4.8 bar, 0.5 MPa)	
(D) = @ 40 psi (2.8 bar, 0.3 MPa)	

TI8645a

Graco Warranties

Graco Standard Pump Warranty

Graco warrants all equipment manufactured by Graco and bearing its name to be free from defects in material and workmanship on the date of sale to the original purchaser for use. With the exception of any special, extended, or limited warranty published by Graco, Graco will, for a period of five years from the date of sale, repair or replace any part of the equipment determined by Graco to be defective. This warranty applies only when the equipment is installed, operated and maintained in accordance with Graco's written recommendations.

This warranty does not cover, and Graco shall not be liable for general wear and tear, or any malfunction, damage or wear caused by faulty installation, misapplication, abrasion, corrosion, inadequate or improper maintenance, negligence, accident, tampering, or substitution of non-Graco component parts. Nor shall Graco be liable for malfunction, damage or wear caused by the incompatibility of Graco equipment with structures, accessories, equipment or materials not supplied by Graco, or the improper design, manufacture, installation, operation or maintenance of structures, accessories, equipment or materials not supplied by Graco.

This warranty is conditioned upon the prepaid return of the equipment claimed to be defective to an authorized Graco distributor for verification of the claimed defect. If the claimed defect is verified, Graco will repair or replace free of charge any defective parts. The equipment will be returned to the original purchaser transportation prepaid. If inspection of the equipment does not disclose any defect in material or workmanship, repairs will be made at a reasonable charge, which charges may include the costs of parts, labor, and transportation.

THIS WARRANTY IS EXCLUSIVE, AND IS IN LIEU OF ANY OTHER WARRANTIES, EXPRESS OR IMPLIED, INCLUDING BUT NOT LIMITED TO WARRANTY OF MERCHANTABILITY OR WARRANTY OF FITNESS FOR A PARTICULAR PURPOSE.

Graco's sole obligation and the buyer's sole remedy for any breach of warranty shall be as set forth above. The buyer agrees that no other remedy (including, but not limited to, incidental or consequential damages for lost profits, lost sales, injury to person or property, or any other incidental or consequential loss) shall be available. Any action for breach of warranty must be brought within six years of the date of sale.

Graco makes no warranty, and disclaims all implied warranties of merchantability and fitness for a particular purpose in connection with accessories, equipment, materials or components sold but not manufactured by Graco. These items sold, but not manufactured by Graco (such as electric motors, switches, hose, etc.), are subject to the warranty, if any, of their manufacturer. Graco will provide purchaser with reasonable assistance in making any claim for breach of these warranties.

In no event will Graco be liable for indirect, incidental, special or consequential damages resulting from Graco supplying equipment hereunder, or the furnishing, performance, or use of any products or other goods sold hereto, whether due to a breach of contract, breach of warranty, the negligence of Graco, or otherwise.

FOR GRACO CANADA CUSTOMERS

The parties acknowledge that they have required that the present document, as well as all documents, notices and legal proceedings entered into, given or instituted pursuant hereto or relating directly or indirectly hereto, be drawn up in English. Les parties reconnaissent avoir convenu que la rédaction du présente document sera en Anglais, ainsi que tous documents, avis et procédures judiciaires exécutés, donnés ou intentés, à la suite de ou en rapport, directement ou indirectement, avec les procédures concernées.

Extended Product Warranty

Graco warrants all 205, 307, 515, 716, 1040, 1590, 2150, 3150, and 3275 air valve center sections to be free from defects in material and workmanship for a period of fifteen years from date installed in service by the original purchaser. Normal wear of items such as packings or seals are not considered to be defects in material and workmanship.

Five years	Graco will provide parts and labor.
Six to Fifteen years	Graco will replace defective parts only.

Graco Information

For the latest information about Graco products, visit www.graco.com.
For patent information, see www.graco.com/patents.

TO PLACE AN ORDER, contact your Graco distributor or call to identify the nearest distributor.
Phone: 612-623-6921 **or Toll Free:** 1-800-328-0211 **Fax:** 612-378-3505

*All written and visual data contained in this document reflects the latest product information available at the time of publication.
Graco reserves the right to make changes at any time without notice.*

Original instructions. This manual contains English. MM 310622

Graco Headquarters: Minneapolis

International Offices: Belgium, China, Japan, Korea

GRACO INC. AND SUBSIDIARIES • P.O. BOX 1441 • MINNEAPOLIS MN 55440-1441 • USA

Copyright 2004, Graco Inc. All Graco manufacturing locations are registered to ISO 9001.

www.graco.com

Revision ZAB - July 2013