

TJR

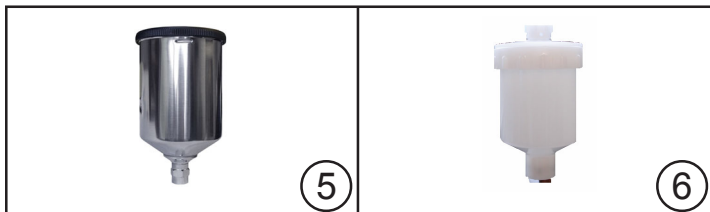
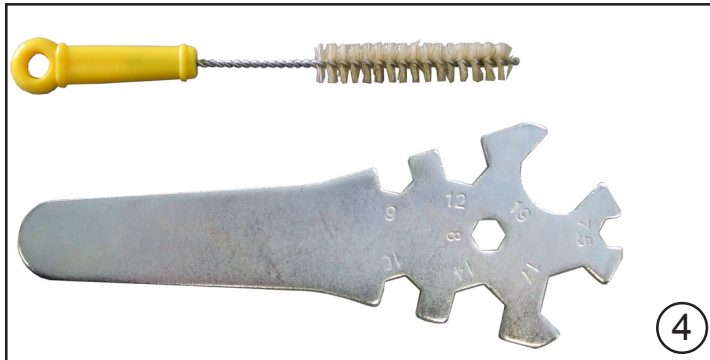
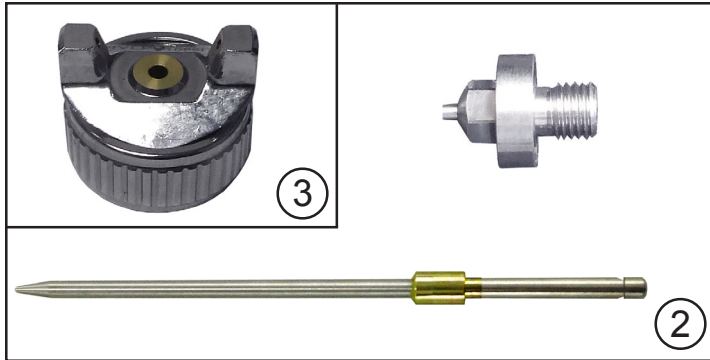

Available CAT Packs

- TJR
- TJR PPS

NEEDLE & NOZZLE SETS

PART NO.	DESCRIPTION
60-TJR-30-08	0.8 mm Needle / Nozzle Set
60-TJR-30-10	1.0 mm Needle / Nozzle Set
60-TJR-30-12	1.2 mm Needle / Nozzle Set

* 1012 needle is used for both the 1.0 and 1.2 nozzle

ITEM NO.	PART NO.	DESCRIPTION	ITEM NO.	PART NO.	DESCRIPTION	Kit
1	TJR	Body Assembly	5	51-406	Aluminum Cup	TJR
2	60-TJR-30-XX	Needle / Nozzle Set*	6	51-407	Plastic Cup	
3	60-TJR-20	Air Cap	7	91-470	Cup and Collar	TJR PPS
4	60-TJR-10-W	Wrench & Brush Kit	8	91-471-50	Lids and Liners (50 Pack)	
Repair Kit	60-TJR-10	Soft Seal Repair Kit	9	91-473	TJR PPS Adapter	

*See Needle & Nozzle Sets Chart

TJR Deluxe

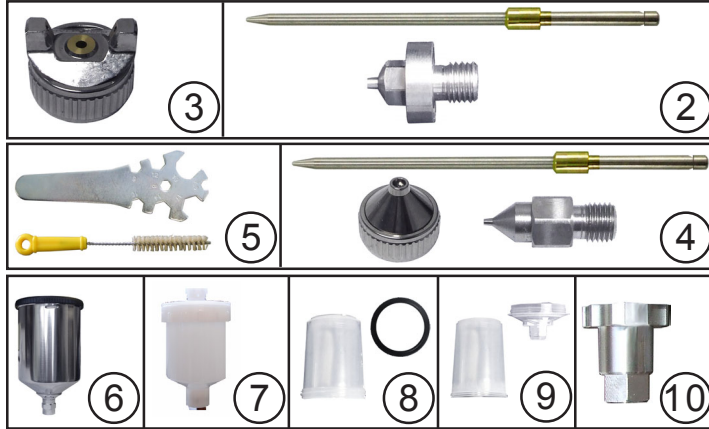

Available CAT Packs

- TJR Deluxe
- TJR Deluxe PPS

NEEDLE & NOZZLE SETS

PART NO.	DESCRIPTION
60-TJR-30-10	1.0 mm Needle / Nozzle Set
60-TJR-30-12	1.2 mm Needle / Nozzle Set

* 1012 needle is used for both the 1.0 and 1.2 nozzle

ITEM NO.	PART NO.	DESCRIPTION	ITEM NO.	PART NO.	DESCRIPTION	Kit
1	TJR	Body Assembly	6	51-406	Aluminum Cup	TJR Deluxe
2	60-TJR-30-XX	Needle / Nozzle Set*	7	51-407	Plastic Cup	
3	60-TJR-20	Air Cap	8	91-470	Cup and Collar	TJR Deluxe PPS
4	60-TJR-21	Round Pattern Kit	9	91-471-50	Lids and Liners (50 Pack)	
5	60-TJR-10-W	Wrench & Brush Kit	10	91-473	TJR PPS Adapter	

*See Needle & Nozzle Sets Chart

(Soft Seal Repair Kit: 60-TJR-10)

TJR Glaze

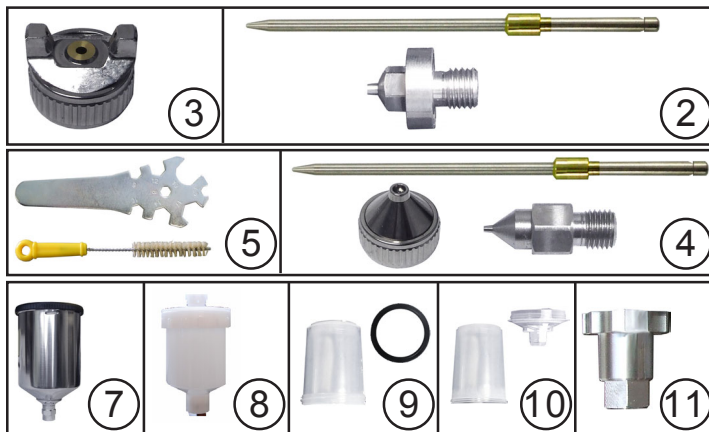

Available CAT Packs

- TJR Glaze
- TJR Glaze PPS

*Inspired by Wayne Smith

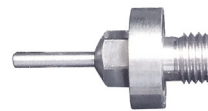

*No air needed when using Glaze Nozzle
*Uses 1.2 needle supplied in kit

ITEM NO.	PART NO.	DESCRIPTION	ITEM NO.	PART NO.	DESCRIPTION	Kit
1	TJR	Body Assembly	7	51-406	Aluminum Cup	TJR Glaze
2	60-TJR-30-12	Needle / Nozzle Set*	8	51-407	Plastic Cup	
3	60-TJR-20	Air Cap	9	91-470	Cup and Collar	TJR Glaze PPS
4	60-TJR-21	Round Pattern Kit	10	91-471-50	Lids and Liners (50 Pack)	
5	60-TJR-10-W	Wrench & Brush Kit	11	91-473	TJR PPS Adapter	
6	60-TJR-30-10-G	Glaze Nozzle 1.0	Repair Kit	60-TJR-10	Soft Seal Repair Kit	

Item 3 (Atomizing Spacer)

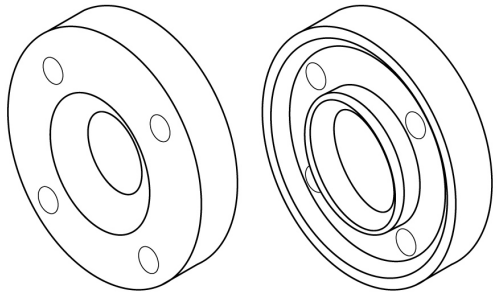

Front
Face towards
Air Cap and
Nozzle

Back
Face towards
the TJR gun
body

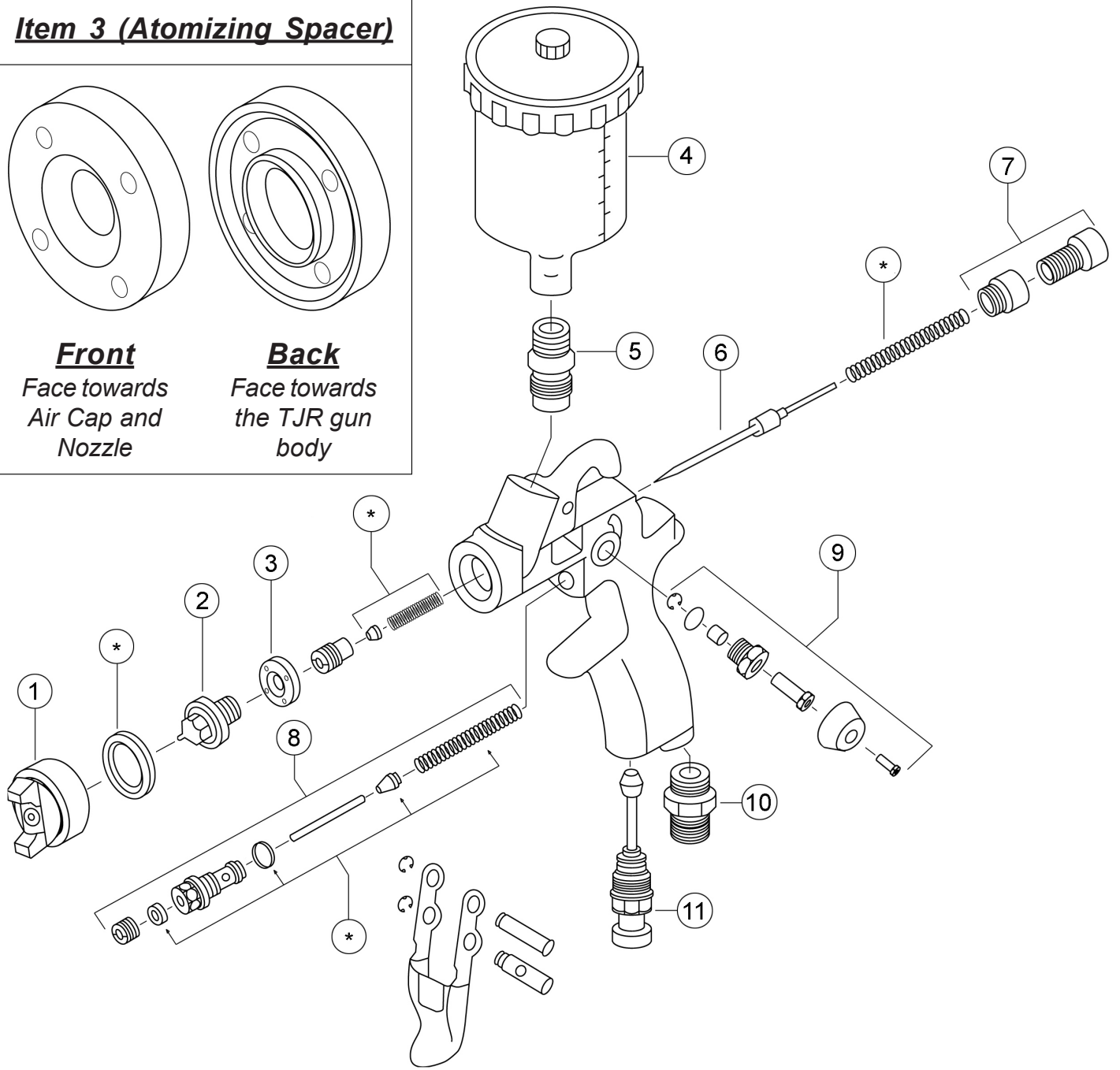

*Indicates part included in repair kit 60-TJR-10

ITEM NO.	PART NO.	DESCRIPTION	ITEM NO.	PART NO.	DESCRIPTION
1	See Page 1 & 2	Air Cap	7	60-TJR-15	Fluid Control Knob / Lock
2	See Page 1 & 2	Nozzle	8	60-TJR-14	Air Valve
3	60-TJR-11	Atomizing Black Spacer	9	60-TJR-12	Fan Control Knob
4	See Page 1 & 2	TJR Gravity Cup	10	60-TJR-18	Air Inlet Fitting
5	60-TJR-16	Fluid Inlet	11	60-TJR-13	Air Control Knob
6	See Page 1 & 2	Needle	*	60-TJR-10	Repair Kit

Operating and Maintenance Instructions for the CAT TJR Spray Gun

Setting Up The TJR Spray Gun

The TJR operates best with 10 PSI at the gun (operating pressure)

The TJR uses 3.5 cfm.

The Tjr is supplied with an air inlet fitting which is 1/4" NPT male. You will need to hook up a suitable length of 5/16" air hose fitted with a 1/4" NPS(F) connection.

Connect the gravity feed cup to the gun by screwing the cup onto the spray gun fluid inlet.

Adjusting Your Spray Gun

There are two means of adjusting air at the gun. The pattern adjusting valve and the air adjusting valve.

Pattern Adjusting Valve

The pattern-adjusting valve regulates air to the "horns" of the gun air cap. Horn air controls the shape of the spray pattern.

1. When the pattern adjusting valve is closed (turned completely clockwise) - a round pattern results.
2. Opening the pattern adjusting valve (turn counter clockwise) produces an increasingly wider and flatter fan pattern.
3. When the maximum spray pattern (widest fan) is achieved, additional turns will not affect the pattern.

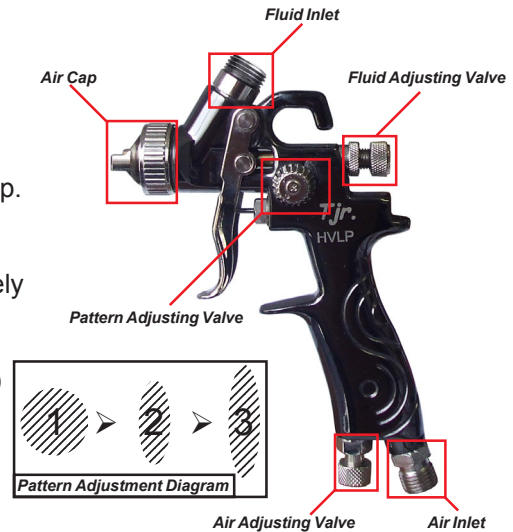

Air Adjusting Valve

The air adjusting valve controls only the flow of air (CFM) to the air cap and has no effect on air pressure (PSI). The valve is often referred to as the "cheater" valve as it is used to restrict air without adjusting the air regulator.

1. Closing the air-adjusting valve (turn counterclockwise) restricts the air flow.
2. Opening the valve (clockwise) increases the volume (flow) of air. This will affect the degree of atomization, but will not change the spray pattern.
3. The air cap (CFM) specification will determine the (CFM) requirements of the gun.

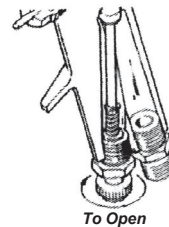

Using 60-TJR-30-10-G (Glaze Nozzle)

When using the new glaze nozzle the first thing you will notice is that there is no air cap, so you will need no air to operate this gun with the glaze setup.

1. Once you have placed the glazing needle and nozzle tightly on the gun, choose the cup you want to use and tighten everything down.
2. Fill the gravity cup with glaze and tighten the lid.
3. Gently press the nozzle tip against the surface you are glazing and pull the trigger.
4. When you come to the point where you no longer want to place the glaze, stop pulling the trigger and the glaze will stop running from the tip.
5. You can also control the size of your glazing strip by turning the fluid control knob.
6. To clean simply pour out unused glaze and flush with solvent.



60-TJR-30-10-G was inspired by Wayne Smith