

MD2 Valve

312185J

ENG

For use with disposable mixers to dispense a variety of sealants and adhesives. For professional use only.

*3000 psi (20.7 MPa, 207 bar) Maximum Working Pressure
120 psi (0.84 MPa, 8.4 bar) Maximum Air Inlet Pressure*



Important Safety Instructions

Read all warnings and instructions in this manual. Save these instructions.

See page 2 for model information, including maximum working pressure and approvals.

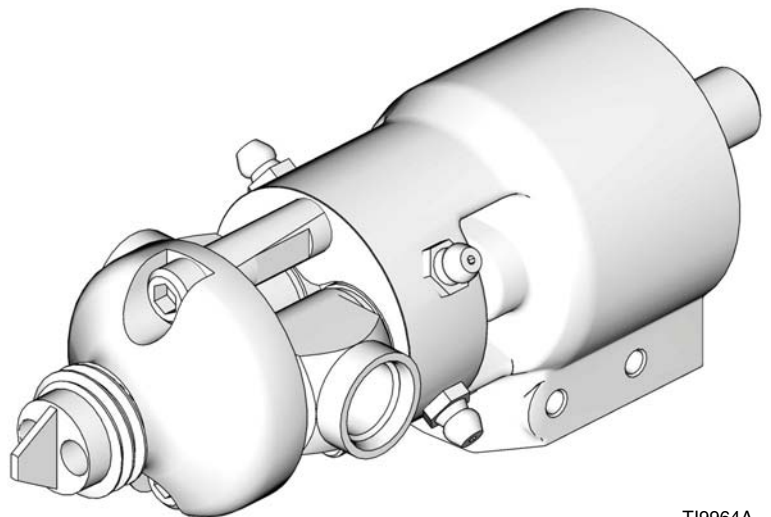

TI9964A

Contents

MD2 Valve Models	2	Troubleshooting	12
Warnings	3	Repair	13
Component Identification	5	Parts	16
Features	6	Accessories	21
Installation	7	Technical Data	25
Setup	8	Dimensions	25
Operation	10	Graco Standard Warranty	26
Maintenance	11	Graco Information	26

MD2 Valve Models

MD2 Valves		
Part No.	Maximum Working Pressure psi (MPa, bar)	Description
255179	3000 psi (20.7 MPa, 207 bar)	1:1 Soft seat, adjustable snuff-back
255180		1:1 Hard seat, non-adjustable snuff-back
255181		Wide ratio, soft seat, adjustable snuff-back
255182		Wide ratio, hard seat, non-adjustable snuff-back
MD2 Valve Handles		
255206	120 psig (0.84 MPa, 8.4 bar)	Air trigger
255208	3A @ 28 VDC	Electric air actuated
255249	0.5 @ 28 VDC	Electric actuated lever





Model Selection

The following table provides a summary of the MD2 dispense valves that are described in this manual.

Type	Description
Hand held valves with internal air trigger	The internal air trigger controls the air piston that operates the MD2 valve. A pilot port can be used to control a pump motor.
Hand held valve with electric switch	The switch signals the customer's controller to open and close the ports on the MD2 valve using a remote 4-way air control valve which is not included.
Wide ratio valves	The wide ratio MD2 valve has a center injection tip. This feature is helpful with wider ratio applications, specifically when the low volume material is a much lower viscosity than the high volume material. Frequent cleaning intervals may be required to maintain the tip.
Hard seats	Carbide seats and hardened needles are good for abrasive materials and stall against pressure applications.
Soft seats	UHMWPE seals are good for precise snuff-back control.

Warnings

The following warnings are for the setup, use, grounding, maintenance, and repair of this equipment. The exclamation point symbol alerts you to a general warning and the hazard symbol refers to procedure-specific risk. Refer back to these warnings. Additional, product-specific warnings may be found throughout the body of this manual where applicable.

 WARNING	
	<p>SKIN INJECTION HAZARD</p> <p>High-pressure fluid from dispense valve, hose leaks, or ruptured components will pierce skin. This may look like just a cut, but it is a serious injury that can result in amputation. Get immediate surgical treatment.</p> <ul style="list-style-type: none"> Do not point dispense valve at anyone or at any part of the body. Do not put your hand over the end of the dispense nozzle. Do not stop or deflect leaks with your hand, body, glove, or rag. Follow Pressure Relief Procedure in this manual, when you stop spraying and before cleaning, checking, or servicing equipment.
	<p>EQUIPMENT MISUSE HAZARD</p> <p>Misuse can cause death or serious injury.</p> <ul style="list-style-type: none"> Do not operate the unit when fatigued or under the influence of drugs or alcohol. Do not exceed the maximum working pressure or temperature rating of the lowest rated system component. See Technical Data in all equipment manuals. Use fluids and solvents that are compatible with equipment wetted parts. See Technical Data in all equipment manuals. Read fluid and solvent manufacturer's warnings. For complete information about your material, request MSDS forms from distributor or retailer. Check equipment daily. Repair or replace worn or damaged parts immediately with genuine manufacturer's replacement parts only. Do not alter or modify equipment. Use equipment only for its intended purpose. Call your distributor for information. Route hoses and cables away from traffic areas, sharp edges, moving parts, and hot surfaces. Do not kink or over bend hoses or use hoses to pull equipment. Keep children and animals away from work area. Comply with all applicable safety regulations.
	<p>TOXIC FLUID OR FUMES HAZARD</p> <p>Toxic fluids or fumes can cause serious injury or death if splashed in the eyes or on skin, inhaled, or swallowed.</p> <ul style="list-style-type: none"> Read MSDS's to know the specific hazards of the fluids you are using. Store hazardous fluid in approved containers, and dispose of it according to applicable guidelines. Always wear impervious gloves when spraying or cleaning equipment.
	<p>PERSONAL PROTECTIVE EQUIPMENT</p> <p>You must wear appropriate protective equipment when operating, servicing, or when in the operating area of the equipment to help protect you from serious injury, including eye injury, inhalation of toxic fumes, burns, and hearing loss. This equipment includes but is not limited to:</p> <ul style="list-style-type: none"> Protective eyewear Clothing and respirator as recommended by the fluid and solvent manufacturer Gloves Hearing protection

 **WARNING**



FIRE AND EXPLOSION HAZARD

Flammable fumes, such as solvent and paint fumes, in **work area** can ignite or explode. To help prevent fire and explosion:

- Use equipment only in well ventilated area.
- Eliminate all ignition sources; such as pilot lights, cigarettes, portable electric lamps, and plastic drop cloths (potential static arc).
- Keep work area free of debris, including solvent, rags and gasoline.
- Do not plug or unplug power cords, or turn power or light switches on or off when flammable fumes are present.
- Ground all equipment in the work area. See **Grounding** instructions.
- Use only grounded hoses.
- Hold gun firmly to side of grounded pail when triggering into pail.
- If there is static sparking or you feel a shock, **stop operation immediately**. Do not use equipment until you identify and correct the problem.
- Keep a working fire extinguisher in the work area.

Component Identification

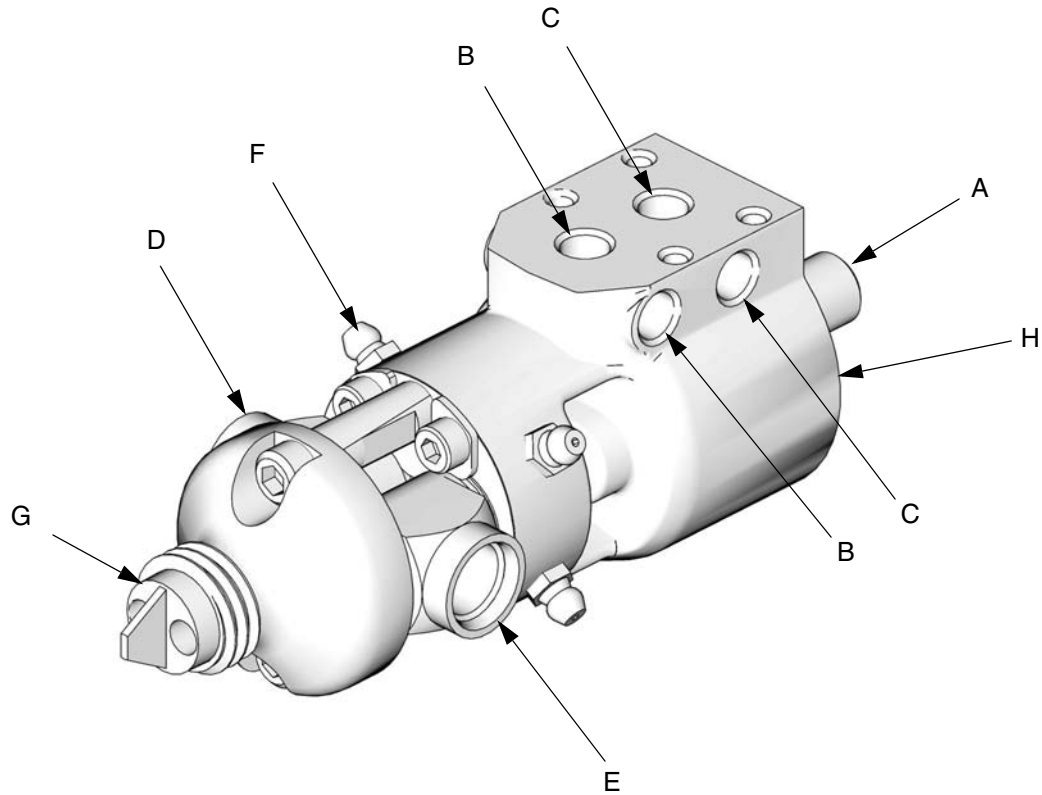

TI10391A

FIG. 1: Component Identification

Key:

- A Snuff-back adjustment knob (soft seat versions only)
- B 1/8 in. npt (f) air to close (O).
- C 1/8 in. npt (f) air to open (I).
- D 9/16-18 UNF (f) (06 SAE) "B" fluid inlet (low volume)
- E 9/16-18 UNF (f) (06 SAE) "A" fluid inlet (high volume)
- F Zerk grease fitting
- G Nosepiece with 7/8-9 bell outlet
- H Air cylinder

Features

Electric Switch Valve

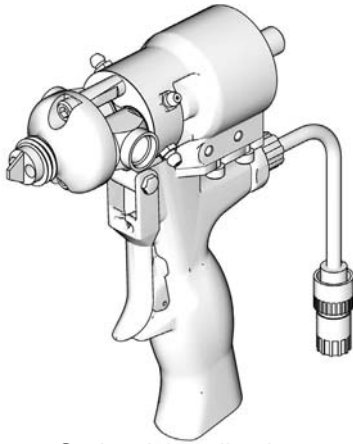

TI10383A

Normally open momentary contact switch

Note: The Trigger/Lever activates an electrical switch in the handle, which activates a remote 4 way solenoid valve. Bring an "OPEN" air signal to the 1/8 in. npt(f) port (I) on this side of the valve, and a "CLOSE" signal to the port (O).

Electric Actuated Lever Valve

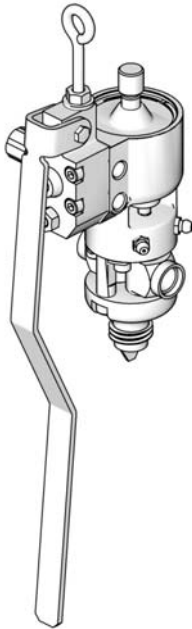

TI10409A

Pneumatic Valve

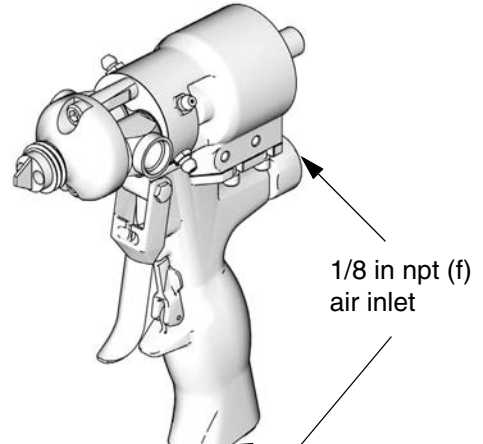

TI10407A

The 1/8 in. npt (f) port (I) can be used to send an "ON" signal back to a pump pilot or control. See FIG. 1.

FIG. 2: Features of the MD2 Valves

Installation

Grounding

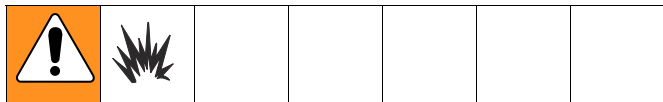

The following grounding instructions are minimum requirements for a basic dispensing system. Your system may include other equipment or objects which must be grounded. Check your local electrical code for detailed grounding instructions for your area and type of equipment. Your system must be connected to a true-earth ground.

- **Pump:** ground the pump by connecting ground wire and clamp as described in your separate pump instruction manual.
- **Air compressors and hydraulic power supplies:** ground the equipment according to the manufacturer's recommendations.
- **Fluid hoses:** use only grounded fluid hoses with a maximum of 500 feet (150 m) combined hose length to ensure grounding continuity. Check the electrical resistance of your fluid hoses at least once a week. If your hose does not have a tag on it which specifies the maximum electrical resistance, contact the hose supplier or manufacturer for the maximum electrical resistance limits, replace the hose immediately.
- **Dispensing valve:** ground the valve by connecting it to a properly grounded fluid hose and pump.
- **Fluid supply container:** ground according to your local code.
- **Flammable liquids in the dispense area:** must be in approved, grounded containers. Do not store more than the quantity needed for one shift.
- **All solvent pails used when flushing:** ground according to local code. Use only metal pails, which are conductive. Do not place the pail on a non-conductive surface, such as paper or cardboard, which interrupts the grounding continuity.
- To maintain grounding continuity when flushing or relieving pressure, hold a metal part of the valve firmly to the side of a grounded metal pail, then trigger the valve.

How to Use the Valve Trigger Safety

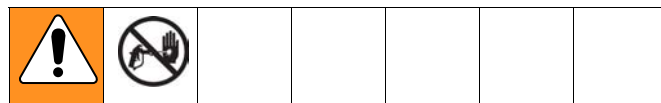

1. If you are using one of the hand-held versions of the valve, lock the valve trigger safety by turning the latch to a right angle with the gun body. See FIG. 4.
2. To unlock the valve trigger safety turn it parallel with the gun body.

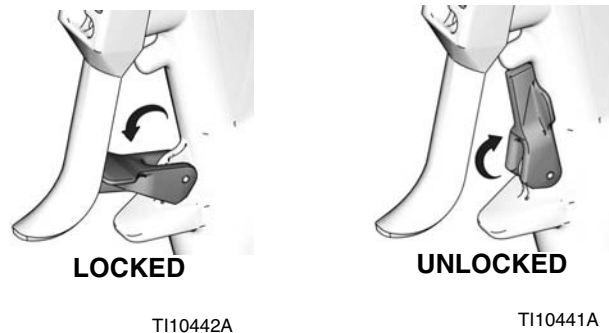

FIG. 3

Setup

Fluid and Air Connections

9/16-18 UNF (f) (06 SAE) Fluid Inlets

There is one fluid inlet on the A-side and one fluid inlet on the B-side. The fluid inlets are located on the side of the valve and swivel to permit various mounting and hose configurations.

1/8 npt(f) Air Inlets

The machine mount valves and the electric switch hand-held valves have an on port (I) and off port (O), which are operated by a remote 4-way air control valve. Use one of the two air inlets located on the bottom and on the back of the valve.

The air switch hand-held valves have a single air inlet with an internal 4-way spool which operates the air piston.

See Accessories on page 17, to order air control valves and tubing.

Inlet Check Valves

Inlet check valves are recommended on the fluid inlets where viscosity allows. An inlet check valve prevents back-flow or crossover when the mixer is plugged or one fluid is much lower viscosity than the other. When required, a high crack pressure check valve is installed to maintain back-pressure on low viscosity fluids.

See Accessories on page 17 for a list of check valves.

Balancing the System

A proportioner is used to feed the two-component dispense valve. The system must be pressure balanced to avoid “lead-lag” ratio errors when starting and stopping the flow.

Balancing is done by hose sizing or inlet check restriction. A properly balanced system has near equal back-pressure on the gauges when flowing without a mixer installed.

Selecting Hoses

Hoses between your proportioner and the MD2 valve should be selected carefully. Many factors effect hose selection.

1. **Fluid Compatibility:** Fluid must not degrade the core material or end fittings of the hose. Nylon or PTFE cores are commonly used for chemical compatibility. If your fluid is moisture sensitive you should use PTFE or Moisture-Lok hoses.
2. **Pressure Rating:** Be sure hoses have a working pressure rating above the pressure capability of the system.
3. **Compressibility:** Hoses, especially nylon paint hoses, expand with an increase in pressure. A pressure change in the system may cause a volume change, which can appear as a ratio error with wide mix ratios. Compressible hoses absorb pressure spikes which is helpful to the operator during an application, such as trying to lay a bead.
4. **Internal Diameter:** Small I.D.'s create higher back pressures, lower flows, and small retained volume. Typically hose I.D.'s are selected for:
 - a. System Pressure Balance. “A” pressure drop vs. “B” pressure drop.
 - b. Volume Balance. A:B volume ratio vs. Hose retained volume.
 - c. Flexibility and weight for operator or robot.
 - d. Overall Pressure Drop. Pressure drop should be minimum possible within the above guidelines.
5. **Length:** Hoses normally are kept as short as practical to minimize pressure drop and compressible volume. 10 ft (3.1 m) is recommended for reciprocating pump systems.

System Start-up

When initially loading the fluids through the system, leave the mixer off until both fluids flow freely from the nose piece without any air. This prevents cross contamination from having fluid on one side pushing back up the other side.

Mixer Selection

Disposable mixers are available from 3/16 in. I.D. to 1/2 in. I.D. in lengths from 12 elements to 36 elements. In general, wide viscosity or mix ratios require more mix elements. Small I.D. mixers produce lower flow, higher back-pressure, and waste little material. Large I.D. mixers produce higher flow, lower back-pressure, and fewer lead-lag ratio errors. Different mixers can have differing snuff-back characteristics.

Setting the Amount of Snuff-back

The MD2 valves with hard seats use two snuff-back restrictor rings (13) to set the amount of snuff-back. These two rings are trapped between the main valve body and the nose piece. When the fluid valve pulls back to close, it enters the restrictions, stops flow, and pulls the fluid back until the needle reaches its carbide seat.

Maximum snuff-back results when both restrictors are used. Some snuff-back is still achieved without the restrictors because of the pull-back action of the needles.

When dispensing wide mix ratios, it is best to use a snuff-back restrictor only on the high volume side. This keeps the high volume side from being pulled back into the low volume side.

The MD2 valves with soft seats have an adjustable snuff-back. Turn the knob on the back of the soft seat MD2 valve to adjust the amount of snuff-back.

In general, use only as much snuff-back as necessary to give a good cut-off of flow. Too much snuff-back pulls an air bubble into the mixer. This can cause a drip, or cause the mixer to spit when the valve is re-opened.

Operation

Pressure Relief Procedure



1. Shut off the air to the supply pumps.
2. Close the bleed-type master air valve (required in your system).
3. Hold a metal part of the valve firmly to the side of a grounded metal pail, and trigger the dispense valve to relieve pressure.
4. Shut off the air to the dispense valve, if applicable.

If you suspect that the dispense needle or hose is completely clogged, or that pressure has not been fully relieved after following the steps above, very slowly loosen the hose end coupling and relieve pressure gradually, then loosen completely. Now clear the needle or hose.

Lever Actuated Valve and Electric Switch Hand-held Valve

- Be sure the air supply lines are connected correctly to the (I) and (O) valve air ports.
- To open or close the valve and maintain the open or closed status, a minimum of 40 psi (280 kPa, 2.8 bar) air pressure must be supplied and maintained at the (I) or (O) port.
- The trigger and lever only activates the electrical switch in the handle, which turns the remote solenoid on and off. See page 18 for electrical diagram.
- Trigger the gun or pull the lever to turn the solenoid on. Release the trigger or lever to turn the solenoid off.

Machine Mount Valve

- Be sure the air supply lines are connected correctly to the ON (I) and OFF (O) valve air ports.
- To open or close the valve and maintain the open or closed status, a minimum of 40 psi (280 kPa, 2.8 bar) air pressure must be supplied and maintained at the ON (I) or OFF (O) port.

- Apply and maintain air pressure to the ON (I) air port on the valve, and remove air pressure from the OFF (O) air port on the valve to open the valve.
- Apply and maintain air pressure to the OFF (O) air port on the valve, and remove air pressure from the ON (I) air port on the valve to close the valve.

Pneumatic Hand-held Valve

The valve operation is such that it is either fully open or fully closed.

The valve is opened and closed by the internal air control valve. Trigger the gun to open the valve. Release the trigger to close the valve.

Ratio Checking

The output mix ratio of your proportioner can be checked by dispensing the two fluids separately out of the nosepiece into tared cups. The cups can then be weighed and the weights divided to get the mix ratio by weight.

Use ratio check nozzles 255247 with 15K688 retaining nut for 1:1 models, or 255245 with 15K688 retaining nut for 10:1 models to make ratio checks.

Ratio checks provide information on the ratio of an overall sample. Transient problems (soft spots) caused by starting and stopping the flow (lead-lag) may not show up in this kind of ratio check. Physical tests of the mixed fluid are the best check of correct ratio and mix quality.

Maintenance

Daily Shutdown

When you are through using the MD2 valve, the outlet to the mixer should be cleaned and protected from drying or crystallization.

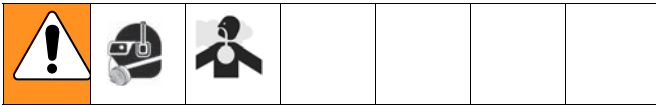

1. Remove and properly dispose of the static mixer.
2. Dispense a shot of material into a waste container to clear any crossover in the nosepiece.
3. Wipe the nose with a clean rag being careful not to let the materials contact each other.
4. Install the PTFE night cap (1:1 valves - 15K652, 10:1 valves - 15K628) and retaining nut (15K688).

Preventive Maintenance

There is a grease filled secondary seal/bearing area on each valve shaft. Every 10,000 cycles, or twice each month, new grease should be flushed across this area.

To grease the valve:

1. Remove the zerk grease fitting from each side of the front or back of the valve.
2. Pump grease (115982) across the valve until grease comes out of the other side.
3. Reinstall the zerk grease fitting.

Troubleshooting



Problem	Cause	Solution
Valve does not open.	Insufficient air pressure.	Turn on air or increase air pressure.
	Air not exhausted from the front side of air cylinder piston.	Use 4-way, relieving type air valve.
Valve does not close and leaks.	Insufficient air pressure.	Turn on air or increase air pressure.
	Air not exhausted from the back side of air cylinder piston.	Use 4-way, relieving type air valve.
	Blockage between needle and seat.	Remove and clean needle and seat.
	Damaged or missing gasket between seat and housing (hard seat only).	Replace gasket (38).
	Damaged or worn needle or seat.	Replace both the needle and seat.
	Too little snuff-back.	Unscrew snuff-back adjustment needle (25) 1/4 turn at a time.
Higher than normal back pressure.	Nose piece is clogged.	Remove and clean.
	Mixer is curing.	Replace mixer.
Soft spots in mixed material.	Nose piece is clogged on one side.	Remove and clean.
	System is not properly balanced.	Balance system with hoses, check valves, restrictors.
	High static pressures build when valve shuts off.	Turn off proportioner pump when valve closes.
Low flow rate.	Snuff-back rings (13) are installed (hard seat only).	Remove snuff-back rings if they are not required for maximum snuff-back.

Repair

Disassembly



1. Relieve all air and fluid pressure, page 10.
2. Disconnect the valve from the system.

NOTE: In the following steps, keep the parts from the A side and B side separate to prevent cured material from forming on them.

3. Remove the two nosepiece screws (19), and pull the nosepiece (29) away from the valve. Remove the needle seats (27) and o-rings (20) for the 255179 and 255181 models. See FIG. 4.
4. Use a 5/32 in. socket or (4mm) to unscrew the needle (25). If the shaft (5) spins, insert a dowel pin in the shaft hole to hold it steady, then unscrew the needle. Slide the seal (26) off the needle. Repeat for the other needle (25).

NOTE: For the 255180 and 255182 models use a 3/32 pin punch to remove the needle, then remove the seats (27) and gaskets (28) from the inlet housing.

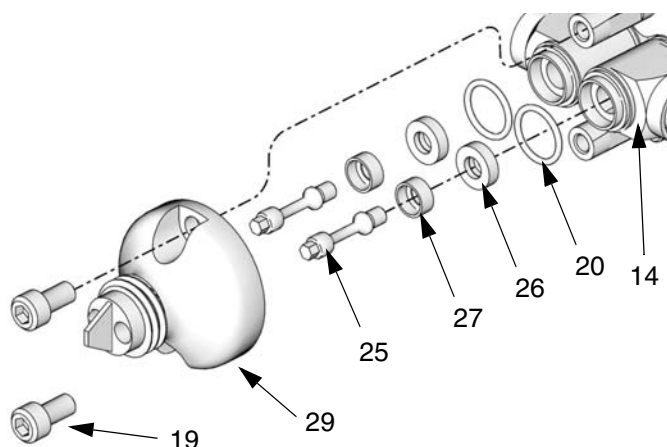

TI9972A

FIG. 4

5. Remove the two fluid housing screws (18) and clamps (17) from the fluid housing (14). Slide the

fluid housing (14) off of the air cylinder (2). See FIG. 5.

6. Remove the bearings (11), bearing o-rings (36, 13), and secondary fluid seals (12, 15).

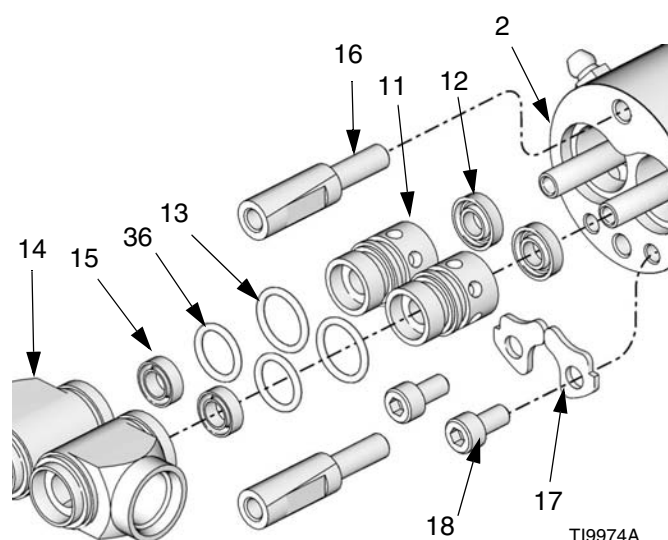

TI9974A

FIG. 5

7. Remove the retaining ring (1) from the back of the air cylinder (2). Push the two shafts (5) into the air cylinder (2) to dislodge the air cylinder cap (22). See FIG. 6.
8. Push the two shafts (5) to dislodge the piston (9) assembly from the air cylinder (2).
9. Use an o-ring pick to remove the o-rings (23) and use a screwdriver to remove the sleeve bearings (7) from the air cylinder (2).
10. Remove the o-rings (6) from the piston (9) and air cylinder cap (22).
11. Remove the screw (24) and snuff-back adjustment knob (21) from the cap (22). Use an o-ring pick to remove the o-ring (23).
12. Remove the lock nuts (3), the pin (8), o-rings (4), and piston o-ring (6) from the shaft (5).

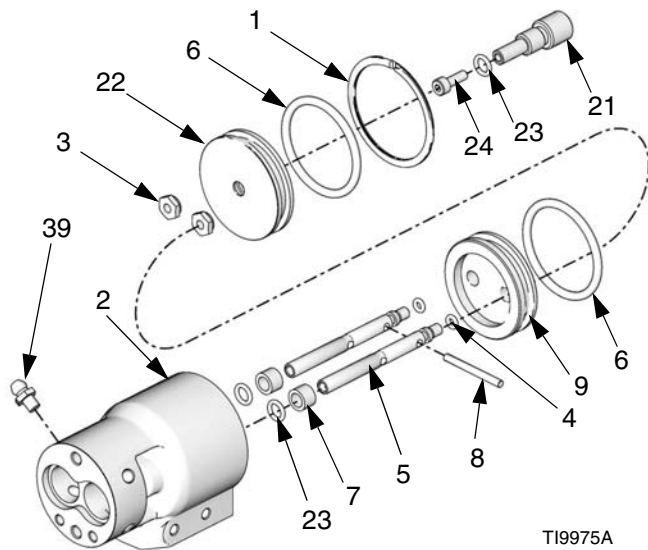

FIG. 6

Pneumatic Handle (if equipped)

1. Remove the four screws (214). Pull the handle (205) and gasket (204) away from the air cylinder (2).
2. Unscrew air valve plug (211) and remove spring (213). Using a small diameter tool, push spool (202) out from front. Inspect o-rings (203).

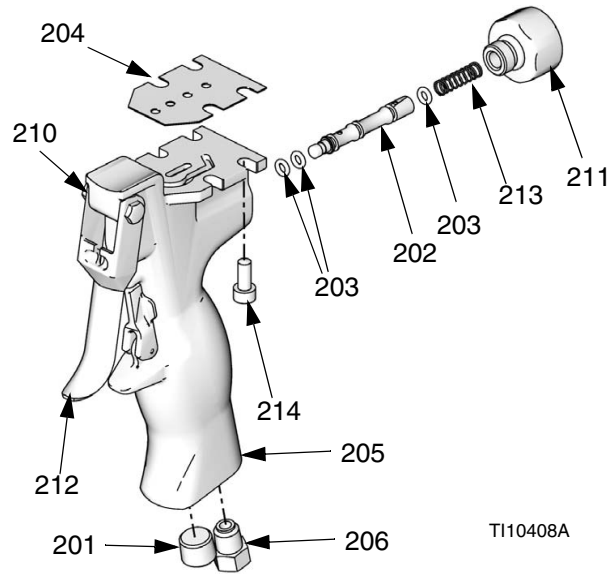

FIG. 7

Electric Switch Handle (if equipped)

1. Disconnect the power from the gun.
2. The switch and cable are not repairable. Replace these parts as a complete assembly. Use kit 255463 for series A handles. Use kit 24D049 for series B handles.
3. Loosen the relief connector (112) and remove the air valve plug (111).
4. Remove the wire which will take the electric switch (114) and spacer (115) with it.

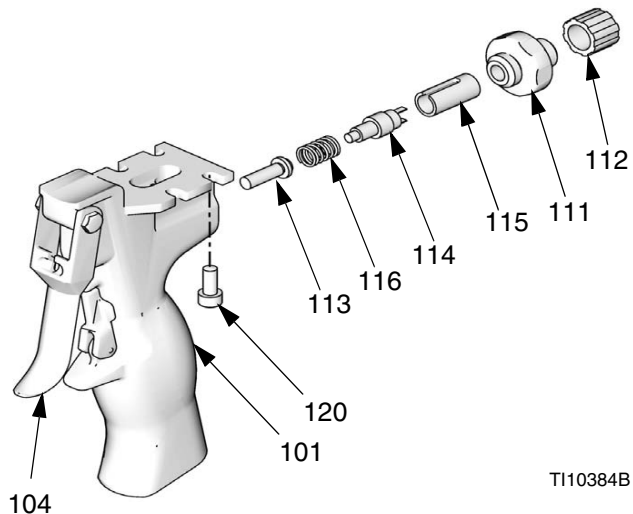

FIG. 8

Reassembly

Air Cylinder Section

1. Lubricate the shaft o-rings (23) and the bearings (7). Insert o-rings into the air cylinder (2) and air cap (22) cavities. See FIG. 6.



NOTE: The snuff-back adjustment knob (21), shaft o-rings (23), and screw (24) are not present in models 255180 and 255182.

2. **255179 and 255182 only:** Insert the snuff-back adjustment knob (21) in the cap (22). Tighten the screw (24) on the end of the snuff-back adjustment knob (21).
3. Press the bearings (7) flush into the air cylinder housing (2) and air cap (22), trapping the o-rings (23).
4. Lubricate and reassemble the piston assembly: piston (9), o-ring (6), dowel pin (8), nuts (3), o-ring (4), and air cylinder shafts (5). Tighten nuts (3) to 25-30 in-lb (2.8-3.4 N•m). The shafts (5) should hang with some play to be self-aligning in the bearing.
5. Lubricate the air cylinder (2) ID. Push the piston (9) assembly into the air cylinder.
6. Lubricate and assemble the o-ring (6) onto cap (22). Push cap (22) into cylinder (2).
7. Install the outside retaining ring (1).

Fluid Section

1. Lubricate the bearings (11), o-rings (13, 36) and seals (12, 15). Put the o-rings (13, 36) on the bearings. Carefully insert the seals (12) into the bearing recess, with the lips of the seals facing into the bearing. Insert the seals (15) into the bearing with the spring facing out of the housing. Be careful not to damage the seal lips. See FIG. 5.
2. Push the bearings (11) into the air cylinder (2).
3. Grease the fluid housing (14) and install over the bearings (11). Install the clamps (17) and screws (18). Tighten to 25-30 in-lb (2.8-3.4 N•m).
4. For 255180 and 255182, insert the gaskets (28) and seats (27).
5. Screw in the needle (25) and tighten it to 15-20 in-lb (1.7-2.2 N•m). See FIG. 4.

6. **255179 and 255181**, Insert the seals (26) with the springs facing into the fluid housing (14).
7. With the “X” on the nosepiece on the same side as the “MD2” on the air cylinder, install the nosepiece (31) with the o-rings (20), seats (27), and nosepiece screws (19). Tighten the nosepiece screws to 25-30 in-lb (2.8-3.4 N•m).
8. **255181 and 255182**, Install injector tube (30) with assembly tool (48). Torque to 168-192 in-lb (19.0-21.7 N•m).
9. **255181 and 255182**, Install injector tip (47) and torque to 60-72 in-lb (6.8-8.1 N•m).
10. Remove zerk grease fitting (39). Fill grease in the grease port below until grease begins to exit where the zerk grease fitting (39) was located. Repeat for the other zerk grease fitting (39). See FIG. 6.

Pneumatic Handle (if equipped)

1. Liberally lubricate o-rings (203) and reassemble. Install spool (202) and spring (213). Torque plug (211) to 125-135 in-lb (14-15 N•m). See FIG. 7.
2. Align the gasket (204) and dispense valve on the top of the handle (205). Torque the four screws (214) evenly to 15-20 in-lb (1.7-2.2 N•m).

Electric Switch

1. Install the plunger (113) and spring (116). See FIG. 8.
2. Insert the switch assembly (255463) while routing the ground lug (108) through the hole in the top of the handle.
3. Torque plug (111) to 125-135 in-lb (14-15 N•m).
4. Tighten the strain relief (112).
5. Install the ground screw (110) through the lock washer (109) and ground lug (108). Torque to 15-20 in-lb (1.7-2.2 N•m).
6. Align the dispense valve on the top of the handle (101). Torque the four screws (120) evenly to 15-20 lb (1.7-2.2 N•m).

Parts

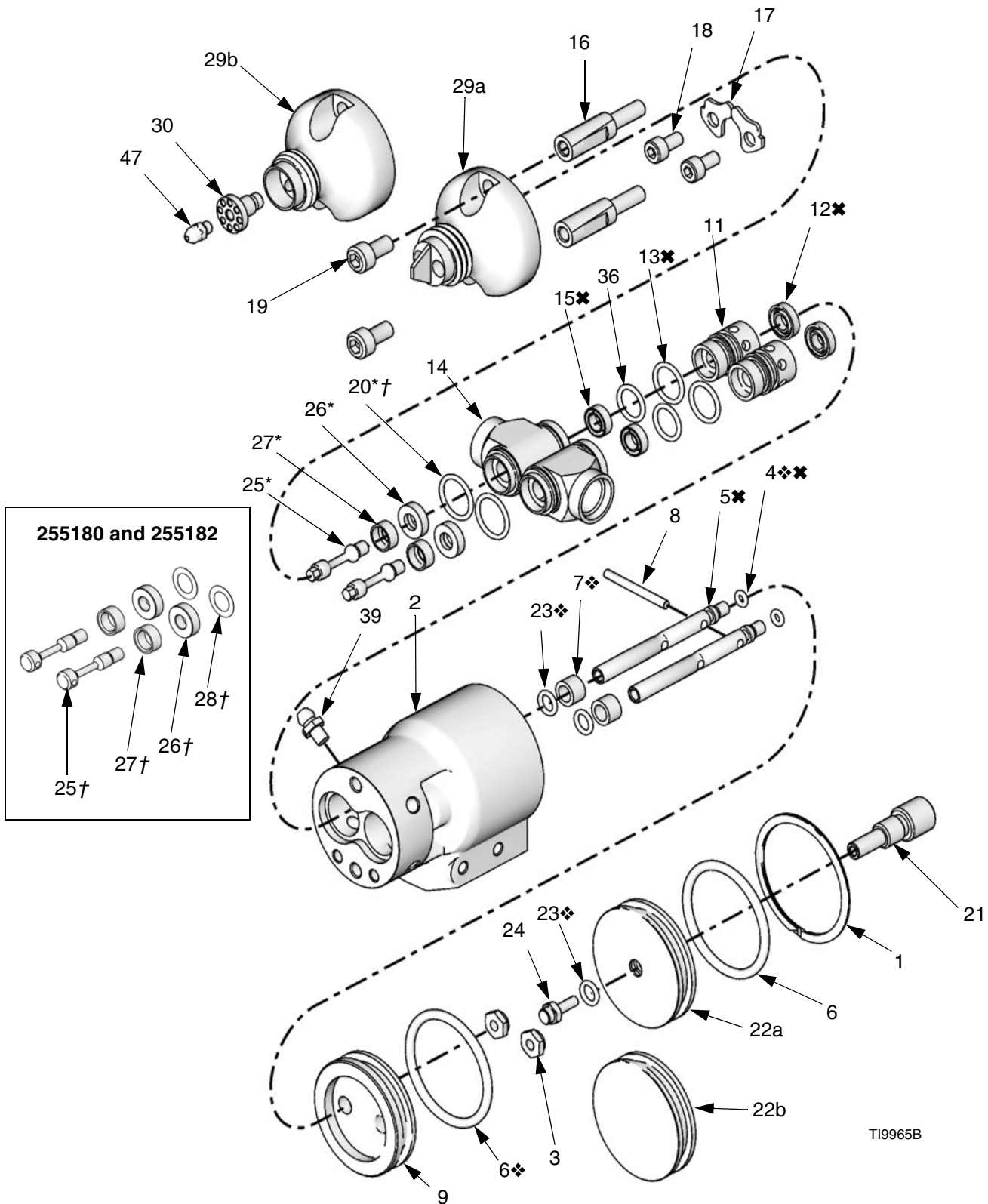

T19965B

MD2 Valve

The parts listed below are common to all MD2 Dispense valves. Parts which vary are found in the table at the bottom of this page.

Ref	Part	Description	Qty
1	120762	RING, retainer	1
2	15K496	HOUSING, air cylinder	1
3	102920	NUT, lock	2
4❖✘	157628	O-RING, buna-n	2
5✘	15K421	SHAFT, primary	2
6❖	156593	O-RING, buna-n	2
7❖	551181	BEARING, sleeve 1/4, 3/8, 1/4, nylon	2
8	551183	PIN, dowel 1/8 x 1.25 18-8 sst	1
9	626067	PISTON, air cylinder	1
11	15K422	BEARING, seal	2
12✘	551191	PACKING, u-cup, nitrile	2
13✘	113746	O-RING	2
14	15K441	HOUSING, inlet	2
15✘	120768	SEAL, UHMWPE	2
16	15K442	SPACER, valve	2
17	15K444	CLAMP, adapter, inlet	2
18	121224	SCREW, cap, socket head, M5 x 0.8 x 8 mm	2

Ref	Part	Description	Qty
19	107530	SCREW, cap, socket head, M6 x1 x 12 mm	2
20*†	117517	O-RING, fluoroelastomer	2
32	15K688	NUT, mixer; not shown	1
33	104765	PLUG, pipe, headless; not shown	2
36	118594	O-RING, fluoroelastomer	2
38	551189	LUBRICANT, grease 3 oz. cartridge; not shown	1
39	120892	FITTING, grease	4
42	299518	CAP, plug	2

❖ *Parts included in Valve Air Cylinder Repair Kit 255217 (purchase separately).*

✘ *Parts included in Valve Lube Seal Repair Kit 255218 (purchase separately).*

* *Parts included in Front Valve Repair Kit 255219 (purchase separately).*

† *Parts included in Front Valve Repair Kit 255220 (purchase separately).*

Ref. No.	Description	1:1	1:1	10:1	10:1	Qty
		255179	255180	255181	255182	
21	KNOB, snuff-back, adjust	15K419		15K419		1
22a	CAP, air cylinder, snuff-back	15K420		15K420		1
22b	CAP, air cylinder		15K447		15K447	1
❖23	O-RING, buna-n	156454(3)	156454(2)	156454(3)	156454(2)	2,3
24	STOP, snuff-back	15V627		15V627		1
25	NEEDLE, snuff-back	*15K428	† 626062	*15K428	† 626062	2
26	SEAL, UHMWPE	*120784	† 185467	*120784	† 185467	2
27	SEAT, needle	*15K460	† 626060	*15K460	† 626060	2
28	GASKET, seat		† 171860		† 171860	2
29a	HOUSING, nose	15K445	15K445			1
29b	HOUSING, nose			15K649	15K649	1
30	TUBE, injector, sst			15V624	15V624	1
31	CAP; not shown	15K652	15K652	15V628	15V628	2
40	ADAPTER, ratio check	255247	255247	256794	256794	1
47	TIP, injector			15V623	15V623	1
48	TOOL, assembly aid			256793	256793	1

Electric Switch Handle, 255208

NOTE: Extension cable 123660 is available.

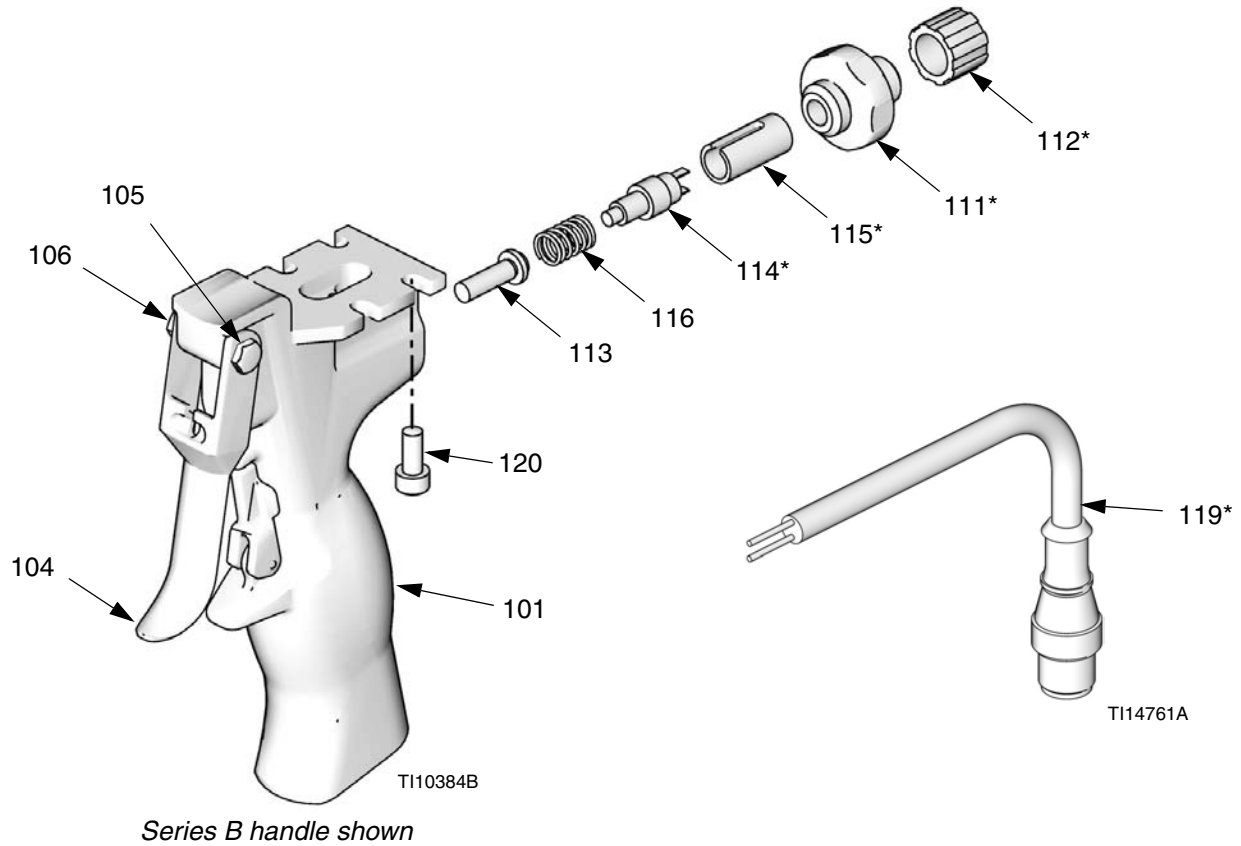

Series B handle shown

Ref	Part	Description	Qty
101	15K666	HANDLE, 2K, dispense valve, electric	1
104	15B209	TRIGGER, gun	1
105	192272	PIN, pivot	1
106	203953	SCREW, cap, hex hd, 10-24 UNC-3A x 3/8	1
111*		PLUG, air valve	1
112*		CONNECTOR, relief 1/4 npt	1
113	15K668	PLUNGER, trigger, 2K handle	1
114*		SWITCH, elect mini snap action	1
115*		SPACER, switch	1
116	551396	SPRING, 0.26X, 0.37X, 0.51 music wire	1
119*		CABLE, trigger, female, 3-pin connector (Series A Handles Only)	1
		CABLE, trigger, male, 4-pin connector (Series B Handles Only)	1
120	117026	SCREW, cap, sch, M5 x 0.80 x 12 mm	4

* Parts included in Series A Handles Kit 255463 and Series B Handles Kit 24D049 (purchase separately).

Pneumatic Handle, 255206

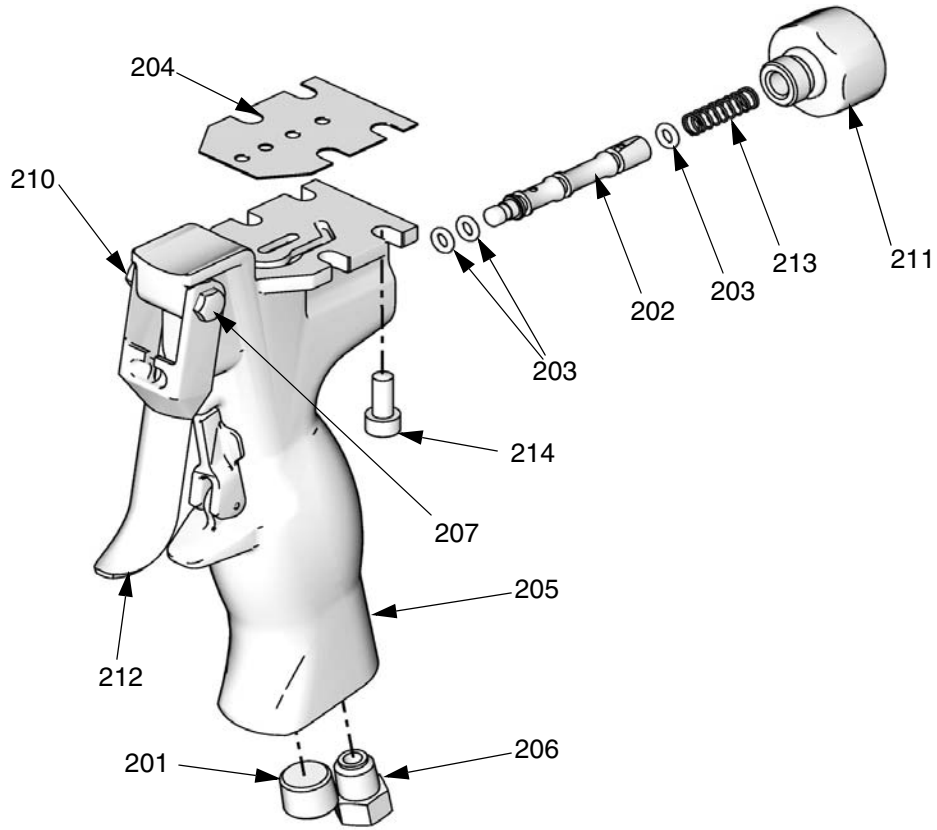

TI10408A

Ref	Part	Description	Qty
201	100721	PLUG, pipe	1
202	15B202	VALVE, spool	1
203	119421	O-RING, chemically resistant fluorocarbon	3
204	15K661	GASKET, handle	1
205	255206	HANDLE, 2K dispense valve, air	1
206	119626	PLUG, breather	1
207	192272	PIN, pivot	1
210	203953	SCREW, cap hex hd, 10-24 UNC-3A x 3/8	1
211	15B208	PLUG, air valve	1
212	15B209	TRIGGER, gun	1
213	117485	SPRING, compression	1
214	117026	SCREW, cap, sch, M5 x 0.80 x 12 mm	4

Actuated Lever, 255249

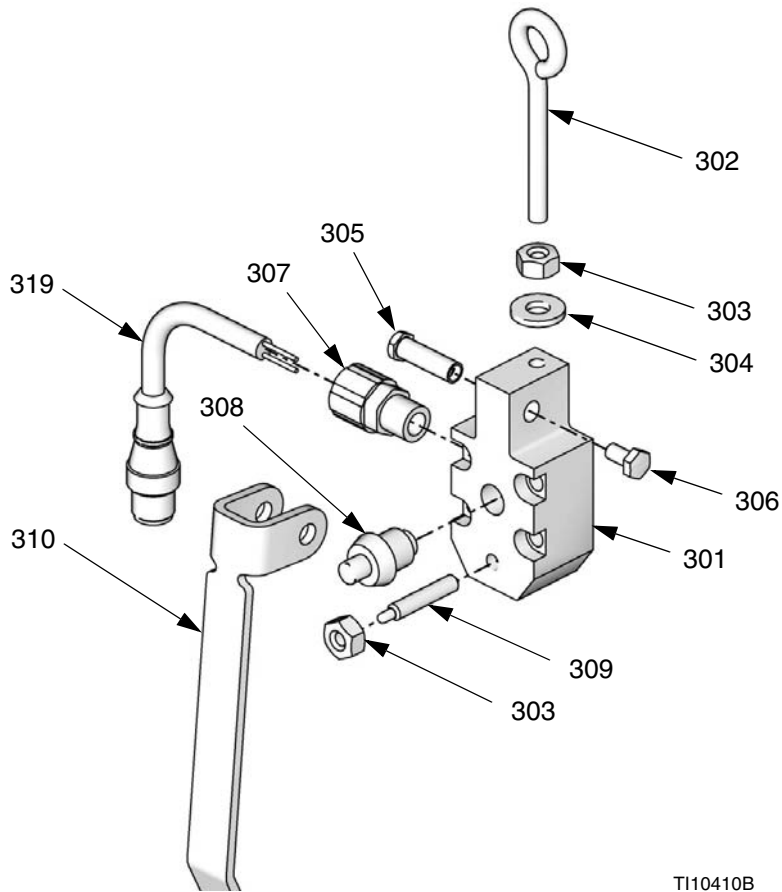

TI10410B

Ref	Part	Description	Qty
301	15K922	BLOCK, mounting lever, 2K	1
302	121191	BOLT, eye, 1/4-20 x 2 in. (51 mm)	1
303	100015	NUT, hex, 1/4-20 UNC 2-B	2
304	100016	WASHER, lock	1
305	192272	PIN, pivot	1
306	203953	SCREW, cap, hex, hd	1
307	551318	CONNECTOR, relief, 1/4 npt	1
308	121192	SWITCH, pushbutton	1
309	121193	PLUNGER, spring, 1/4-20	1
310	15M479	LEVER, actuator, valve	1
311	121194	SCREW, socket head cap, M5 - 0.8 x 30 mm (not shown)	4
319		CABLE, trigger, female, 3-pin connector	1

Accessories

Plastic Tube Fittings to Connect Air Signals

Tube OD	1/8 NPT (M) Straight	1/8 NPT (M) 90° Swivel
5/32 in.	114263	114151
1/4 in.	115671	112698
Tube OD	1/4 NPT (M) Straight	1/4 NPT (M) 90° Swivel
5/32 in.	598252	114469
1/4 in.	104165	114109

Inlet Check Valves (3000 psi working pressure)

Part No.	Size	Description
501867	1/4 NPT (M x M)	303 sst with PTFE o-ring poppet (2 psi crack pressure).
501684	3/8 NPT (M x M)	303 sst with PTFE o-ring poppet (2 psi crack pressure).
949709	3/8 NPT (M x M)	Carbon steel carbide seat (50 psi crack pressure).
949710	3/8 NPT (M x M)	Carbon steel carbide seat (100 psi crack pressure).

Catalyst Injectors

Catalyst injectors are restrictive check valves which are often used to create back pressure on the catalyst side inlet to the MD2 valve. Catalyst injectors are also used to balance pressures and flow on wide-ratio, low-viscosity catalyst applications.

Injector No.	Size Code	Bore Dia.	Needle Dia.	Typical Application Viscosity	Typical Used Sealant*
948291	#125	0.125 in.	0.086 in.	500-50,000 cps	Polysulfide
948258	#35	0.110 in.	0.086 in.	1000-10,000 cps	Silicone
947937	#40	0.098 in.	0.086 in.	200-1,500 cps	Urethane
570251	#42	0.0935 in.	0.086 in.	50-800 cps	Urethane

* Wide ratio applications 8:1 to 13:1 by volume.

** Injectors have a “snout” and must be screwed into a 1/4 npt(f) female coupling. Inlet is 1/4 npt(f).

Plastic Tubing for Air Signal Lines

Part No.	Description
514607	5/32 in. O.D. Nylon
C12509	1/4 in. O.D. Nylon

Mixers and Shroud

ID x # elements	50 pack	250 pack	Shroud
3/16 x 32	LC0077	LC0084	LC0063
1/4 x 24	LC0078	LC0085	LC0057
3/8 x 24	LC0079	LC0086	LC0058
3/8 x 36	LC0080	LC0087	LC0059
3/8 Combo	LC0081	LC0088	LC0060
3/16 x 32 Luer Lock	LC0082	LC0089	LC0061
1/4 x 24 Luer Lock	LC0083	LC0090	LC0062

Nose Piece Accessories

Part No.	Description	Notes
15K652	1:1 nightcap	PTFE cap to protect the 1:1 outlet when not in use
15V628	10:1 nightcap	PTFE cap to protect the 10:1 outlet when not in use
255247	1:1 ratio check nozzle	Splits the flow on 1:1 valves to facilitate ratio checks
256794	10:1 ratio check nozzle	Splits the flow on 10:1 valves to facilitate ratio checks
258687	10:1 check tip	Assembly for low volume side material that is very thin
256793	Tool	Assembly tool to aid in the installation and removal of injector tube 15V623
15K688	7/8-9 retaining nut	Use to hold 15K652, 255247 and 255245 on to valve

Orifice Kits

In the following table, shaded rows indicate “Super Standard” items that are typically stocked and provide the best delivery dates.

Impingement Port Size		Kit Type and Kit Number	
		250 Model Polyol Orifice Kit	250 Model Iso Orifice Kit
in.	mm		
0.016	0.41	24C805	24D229
0.020	0.51	24C751	24D223
0.024	0.61	24C806	24D230
0.028	0.71	24C807	24D231
0.031	0.79	24C752	24D224
0.035	0.89	24C808	24D232
0.039	0.99	24C809	24D233
0.042	1.07	24C810	24D234

Impingement Port Size		Kit Type and Kit Number	
		250 Model Polyol Orifice Kit	250 Model Iso Orifice Kit
in.	mm		
0.047	1.19	24C753	24D225
0.052	1.32	24C811	24D235
0.055	1.40	24C812	24D236
0.060	1.52	24C754	24D226
0.063	1.60	24C813	24D237
0.067	1.70	24C755	24D227
0.073	1.85	24C815	24D238
0.086	2.18	24C756	24D228

24E505 Orifice Block Kit

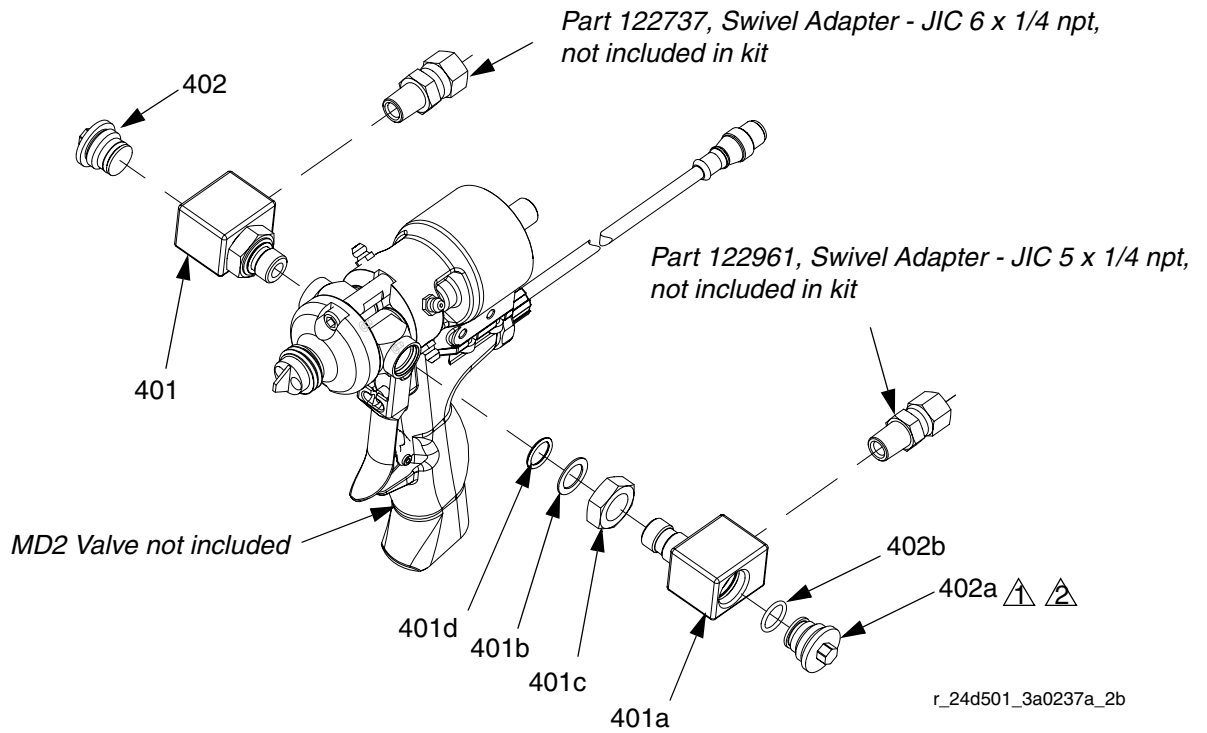

 Lubricate all o-rings and specified surfaces.

 Torque to 20-30 in-lbs (2.2-3.4 N•m).

Ref.	Part	Description	Qty.
401	24D739	HOUSING, orifice, assy; includes 401a-401d	1
401a		HOUSING, orifice	1
401b		WASHER	1
401c		NUT	1
401d	123886	O-RING	1
402	24E569	KIT, orifice block plug; includes 402a and 402b	1
402a	16C339	PLUG, orifice	1
402b	117724	O-RING	1

*24E505 does not include an MD2 valve. See **MD2 Valve Models** on page 2.*

24E505 does not include swivel adapters. Swivel adapters 122961 and 122737 must be purchased separately.

See manual 3A0861 for ratio check assembly 24F227.

Valve Accessories

551351 Short Throw Spacer

A spacer under the air piston that limits how far the fluid needles push open. It reduces the amount of material surge when the valve opens, and reduces the amount of snuff-back available. Used for dispensing low flow small diameter beads. For 255180 and 255182 only.

123660 Extension Cable, 6.0 m (19.7 ft)

For locating the valve further from the base system than allowed with the original cable provided. For use with the electric handle 255208 and actuated lever 255249.

Conversion Kits

Part No.	Description	Notes
255206	Pneumatic Handle	Convert any valve to a hand held valve with an internal pneumatic 4-way valve. See page 19.
255208	Electric Handle	Convert any valve to a hand held valve with an internal normally open switch. See page 18.
255249	Electric Lever Switch	Convert any valve to a hanging valve with an internal normally open switch. See page 20.
255273	Hanger Adapter	Add to any hand held valve to allow it to be hung.
123902	Cable	Replaces trigger cable included with electric handle 255208 and actuated lever 255249. For converting handle/lever to connect to systems previously connected to a TwinMixer [®] gun. Use pins 1 (brown) and 3 (blue).

Front Valve Repair Kits

Part No.	Description
255219	Repair Kit for adjustable snuff-back valves 255179 and 255181 only.
255220	Repair Kit for non-adjustable snuff-back valves 255180 and 255182 only.

Hanger Adapter

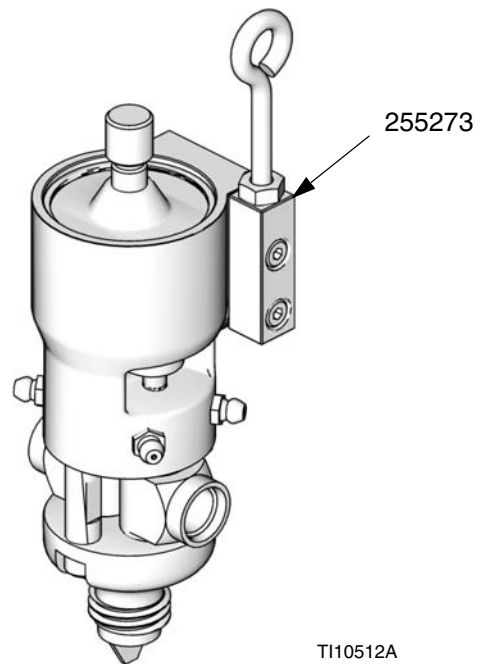

T110512A

Technical Data

Maximum Fluid Pressure
 Maximum Cylinder Air Pressure
 Air Inlets (open (I) and close (O) ports)
 Fluid Inlets
 Fluid Outlet

Fluid Viscosity Range

Soft Seats
 Hard Seats
 Fluid Section Sealing
 Divorced Air Cylinder

Weight

255179 / 255180 (1:1 valves)
 255181 / 255182 (10:1 valves)
 255206 (pneumatic handle)
 255208 (electric handle)
 255249 (electric lever)

Wetted Parts

Stainless Steel Valve

3000 psi (20.7 MPa, 207 bar)
 120 psi (0.84 MPa, 8.4 bar)
 1/8 npt(f)
 9/16-18 UNF (f) (06 SAE) "A" and "B"
 7/8-9 bell outlet

1-1 million cps
 20-1 million cps
 Isolation chamber with zerk fittings and dual seals.
 Double acting, buna-n o-rings

1.45 lb (0.66 kg)
 1.50 lb (0.68 kg)
 0.85 lb (0.39 kg)
 0.90 lb (0.41 kg)
 0.75 lb (0.34 kg)

303 sst, 17-4 SS, UHMWPE, PEEK, Chemical Resistant o-rings. 440C SS and C2 carbide with cobalt binder (hard seat only)

Dimensions

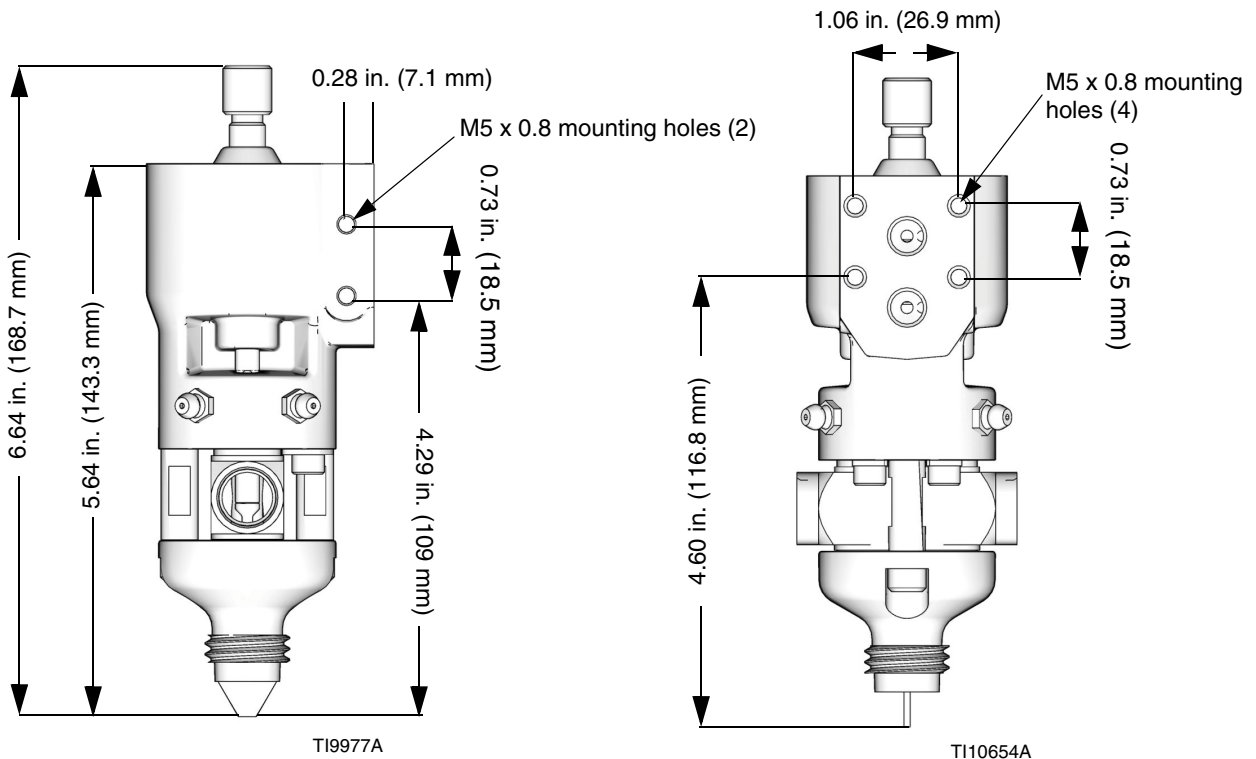

Graco Standard Warranty

Graco warrants all equipment referenced in this document which is manufactured by Graco and bearing its name to be free from defects in material and workmanship on the date of sale to the original purchaser for use. With the exception of any special, extended, or limited warranty published by Graco, Graco will, for a period of twelve months from the date of sale, repair or replace any part of the equipment determined by Graco to be defective. This warranty applies only when the equipment is installed, operated and maintained in accordance with Graco's written recommendations.

This warranty does not cover, and Graco shall not be liable for general wear and tear, or any malfunction, damage or wear caused by faulty installation, misapplication, abrasion, corrosion, inadequate or improper maintenance, negligence, accident, tampering, or substitution of non-Graco component parts. Nor shall Graco be liable for malfunction, damage or wear caused by the incompatibility of Graco equipment with structures, accessories, equipment or materials not supplied by Graco, or the improper design, manufacture, installation, operation or maintenance of structures, accessories, equipment or materials not supplied by Graco.

This warranty is conditioned upon the prepaid return of the equipment claimed to be defective to an authorized Graco distributor for verification of the claimed defect. If the claimed defect is verified, Graco will repair or replace free of charge any defective parts. The equipment will be returned to the original purchaser transportation prepaid. If inspection of the equipment does not disclose any defect in material or workmanship, repairs will be made at a reasonable charge, which charges may include the costs of parts, labor, and transportation.

THIS WARRANTY IS EXCLUSIVE, AND IS IN LIEU OF ANY OTHER WARRANTIES, EXPRESS OR IMPLIED, INCLUDING BUT NOT LIMITED TO WARRANTY OF MERCHANTABILITY OR WARRANTY OF FITNESS FOR A PARTICULAR PURPOSE.

Graco's sole obligation and buyer's sole remedy for any breach of warranty shall be as set forth above. The buyer agrees that no other remedy (including, but not limited to, incidental or consequential damages for lost profits, lost sales, injury to person or property, or any other incidental or consequential loss) shall be available. Any action for breach of warranty must be brought within two (2) years of the date of sale.

GRACO MAKES NO WARRANTY, AND DISCLAIMS ALL IMPLIED WARRANTIES OF MERCHANTABILITY AND FITNESS FOR A PARTICULAR PURPOSE, IN CONNECTION WITH ACCESSORIES, EQUIPMENT, MATERIALS OR COMPONENTS SOLD BUT NOT MANUFACTURED BY GRACO. These items sold, but not manufactured by Graco (such as electric motors, switches, hose, etc.), are subject to the warranty, if any, of their manufacturer. Graco will provide purchaser with reasonable assistance in making any claim for breach of these warranties.

In no event will Graco be liable for indirect, incidental, special or consequential damages resulting from Graco supplying equipment hereunder, or the furnishing, performance, or use of any products or other goods sold hereto, whether due to a breach of contract, breach of warranty, the negligence of Graco, or otherwise.

FOR GRACO CANADA CUSTOMERS

The Parties acknowledge that they have required that the present document, as well as all documents, notices and legal proceedings entered into, given or instituted pursuant hereto or relating directly or indirectly hereto, be drawn up in English. Les parties reconnaissent avoir convenu que la rédaction du présente document sera en Anglais, ainsi que tous documents, avis et procédures judiciaires exécutés, donnés ou intentés, à la suite de ou en rapport, directement ou indirectement, avec les procédures concernées.

Graco Information

For the latest information about Graco products, visit www.graco.com.

TO PLACE AN ORDER, contact your Graco distributor or call to identify the nearest distributor.

Phone: 612-623-6921 **or Toll Free:** 1-800-328-0211 **Fax:** 612-378-3505

*All written and visual data contained in this document reflects the latest product information available at the time of publication.
Graco reserves the right to make changes at any time without notice.*

Original instructions. This manual contains English. MM 312185

Graco Headquarters: Minneapolis

International Offices: Belgium, China, Japan, Korea

GRACO INC. P.O. BOX 1441 MINNEAPOLIS, MN 55440-1441

Copyright 2007, Graco Inc. is registered to ISO 9001

www.graco.com

Revised 6/2011