

1:1 Extruder

310726G

ENG

Supply, metering and dispense system for 5 gallon (20 Liter) pails. For professional use only.

Not for use in explosive atmospheres.

Part No. 965119

1:1 Extruder President® Check-Mate® 200 System, carbon steel

Part No. 570135

1:1 Extruder President® Check-Mate® 200 System, stainless steel

2000 psi (14 MPa, 140 bar) Pump Maximum Working Pressure

90 psi (621 kPa, 6.3 bar) Pump Maximum Air Inlet Pressure

150 psi (1 MPa, 10 bar) Ram Maximum Air Inlet Pressure



Important Safety Instructions





Read all warnings and instructions in this manual. Save these instructions.





Table Of Contents

- Warnings 2
- Grounding 4
- Operation 4
 - Pressure Relief Procedure 5
 - Initial Startup 5
 - Dispensing Mixed Material 5
 - Shutdown 5
- Part No. 965119 6
- Part No. 965119 7
- Part No. 570135 8
- Part No. 570135 9
- Technical Specifications 10
 - Part No. 570135 10
 - Part No. 965119 10
- Mounting Footprint 11
 - Part No. 570135 and 965119 11
- Graco Standard Warranty 12
- Graco Information 12

Warnings

The following warnings include general safety information for this equipment. More specific warnings are in the text where applicable.

 WARNING	
 	<p>SKIN INJECTION HAZARD</p> <p>High-pressure fluid from gun, hose leaks, or ruptured components will pierce skin. This may look like just a cut, but it is a serious injury that can result in amputation. Get immediate surgical treatment.</p> <ul style="list-style-type: none"> • Do not point gun at anyone or at any part of the body. • Do not put your hand over the spray tip. • Do not stop or deflect leaks with your hand, body, glove, or rag. • Do not spray without tip guard and trigger guard installed. • Engage trigger lock when not spraying. • Follow Pressure Relief Procedure in this manual, when you stop spraying and before cleaning, checking, or servicing equipment.
	<p>FIRE AND EXPLOSION HAZARD</p> <p>Flammable fumes, such as solvent and paint fumes, in work area can ignite or explode. To help prevent fire and explosion:</p> <ul style="list-style-type: none"> • Use equipment only in well ventilated area. • Eliminate all ignition sources; such as pilot lights, cigarettes, portable electric lamps, and plastic drop cloths (potential static arc). • Keep work area free of debris, including solvent, rags and gasoline. • Do not plug or unplug power cords, or turn power or light switches on or off when flammable fumes are present. • Ground equipment and conductive objects in work area. See Grounding instructions. • Use only grounded hoses. • Hold gun firmly to side of grounded pail when triggering into pail. • If there is static sparking or you feel a shock, stop operation immediately. Do not use equipment until you identify and correct the problem.
	<p>EQUIPMENT MISUSE HAZARD</p> <p>Misuse can cause death or serious injury.</p> <ul style="list-style-type: none"> • Do not exceed the maximum working pressure or temperature rating of the lowest rated system component. See Technical Data in all equipment manuals. • Use fluids and solvents that are compatible with equipment wetted parts. See Technical Data in all equipment manuals. Read fluid and solvent manufacturer's warnings. • Check equipment daily. Repair or replace worn or damaged parts immediately. • Do not alter or modify equipment. • For professional use only. • Use equipment only for its intended purpose. Call your Graco distributor for information. • Route hoses and cables away from traffic areas, sharp edges, moving parts, and hot surfaces. • Do not use hoses to pull equipment. • Comply with all applicable safety regulations.

 WARNING	
	<p>MOVING PARTS HAZARD</p> <p>Moving parts can pinch or amputate fingers and other body parts.</p> <ul style="list-style-type: none"> • Keep clear of moving parts. • Do not operate equipment with protective guards or covers removed. • Pressurized equipment can start without warning. Before checking, moving, or servicing equipment, follow the Pressure Relief Procedure in this manual. Disconnect power or air supply.
	<p>TOXIC FLUID OR FUMES HAZARD</p> <p>Toxic fluids or fumes can cause serious injury or death if splashed in the eyes or on skin, inhaled, or swallowed.</p> <ul style="list-style-type: none"> • Read MSDS's to know the specific hazards of the fluids you are using. • Store hazardous fluid in approved containers, and dispose of it according to applicable guidelines.
	<p>PERSONAL PROTECTIVE EQUIPMENT</p> <p>You must wear appropriate protective equipment when operating, servicing, or when in the operating area of the equipment to help protect you from serious injury, including eye injury, inhalation of toxic fumes, burns, and hearing loss. This equipment includes but is not limited to:</p> <ul style="list-style-type: none"> • Protective eyewear • Clothing and respirator as recommended by the fluid and solvent manufacturer • Gloves • Hearing protection

Grounding

⚠ WARNING



Your system must be grounded. Read warnings, page 2.

Pump: use ground wire and clamp. Loosen grounding lug locknut (A) and washer (B). Insert 12 gauge minimum ground wire end (D) into lug slot (C) and tighten locknut securely. Connect ground clamp to a true earth ground.

Air and fluid hoses: use only electrically conductive hoses. Check electrical resistance of hoses once a week. Refer to the hose tag or contact supplier for maximum resistance limits. If total resistance to ground exceeds limits, replace hose immediately.

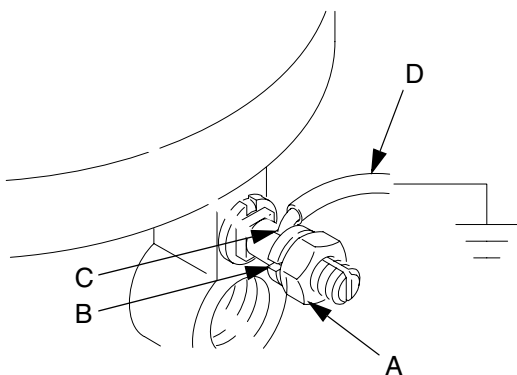

FIG. 1

Air compressor: follow manufacturer's recommendations.

Spray gun / Dispense valve: ground through connection to a properly grounded fluid hose and pump.

Fluid supply container: follow local code.

Object being sprayed: follow local code.

Solvent pails used when flushing: follow local code. Use only conductive metal pails, placed on a grounded surface. Do not place the pail on a nonconductive surface, such as paper or cardboard, which interrupts grounding continuity.

To maintain grounding continuity when flushing or relieving pressure: hold metal part of the spray gun/dispense valve firmly to the side of a grounded metal pail, then trigger the gun/valve.

Operation

⚠ WARNING



Keep your fingers, hands, and tools away from the priming piston and the air motor piston during operation and whenever the pump air and fluid pressure is not fully relieved. The pump priming piston extends below the foot valve during operation and could pinch or amputate your fingers or hands as it moves up into the cylinder.

Be sure all moving part shields are installed and safety devices are operating properly before each use.

⚠ WARNING



Tighten all fluid connections securely before each use. High pressure fluid can dislodge a loose coupling or allow high pressure spray to be emitted from the coupling.

CAUTION

Never operate one pump alone. Do not disconnect one pump or allow a pump to run out of material. The system is designed to have both pumps run together. Running one pump alone puts too much stress on the hardware that connects the air motor to the displacement pumps and could cause the hardware to fracture.

Pressure Relief Procedure

WARNING



Follow **Pressure Relief Procedure** when you stop dispensing and before cleaning, checking, or servicing equipment. Read warnings, page 2.

1. Engage trigger lock.
 2. Turn off air to the pump air motor.
 3. Disengage the trigger lock.
 4. Hold a metal part of the gun firmly to a grounded metal pail. Trigger the gun to relieve pressure.
 5. Engage the trigger lock.
 6. Open all fluid drain valves in the system, having a waste container ready to catch drainage. Leave drain valve(s) open until you are ready to dispense again.
 7. If you suspect the spray tip or hose is clogged or that pressure has not been fully relieved after following the steps above, **VERY SLOWLY** loosen tip guard retaining nut or hose end coupling to relieve pressure gradually, then loosen completely. Clear hose or tip obstruction.
6. Stand clear of the pumps. Turn the ram control to **DOWN**. When the ram plates enter the pails and material comes out the vents, close the vent valves. Set the ram down pressure to at least 50 psi (345 kPa, 3.4 bar). More pressure can be used for high viscosity materials.
 7. Remove the mixer if one is installed.
 8. Open the outlet valves on the hoses.
 9. Set the President air motor regulator to 40 psi (276 kPa, 2.8 bar). Slowly open the pump control air valve just until the pumps start moving. (Some air will escape while the valve is partially open.) When the pumps are primed and filling the hoses, the pump control air valve can be fully opened. When both materials are coming through the outlets free of test oil, close the dispense valve.

Initial Startup

1. Connect a 1/2 in. (12.7 mm) air hose to the main air inlet connection.
2. Connect the dispense valve kit.
3. Raise the pneumatic ram:
 - a. Turn the ram control to UP.
 - b. Turn the ram air regulator up until the pumps begin to rise.
4. Open a pail of component A and B. Place the pails in their proper spots on the frame assembly pail levelers. Hook the pail handles over the nearby frame bolts.
5. Open the pail ram plate vent valves.

Dispensing Mixed Material

1. Install a mixer on the outlet valve.
2. Set pump motor valve to the ON position.
3. Open dispense valve. Adjust President air motor regulator from 40–120 psi (0.28–0.8 MPa, 2.8–8 bar) to obtain desired flow rate.

Shutdown

When you are done dispensing, remove the disposable mixer, and wipe off the outlet. Depending on what type of material you are dispensing, it may be better to leave the mixer on until the next time you use the equipment, or it may be necessary to not only wipe off the outlet but to seal it from air. Part No. 551327 plastic disposable caps are available for this purpose.

Part No. 965119

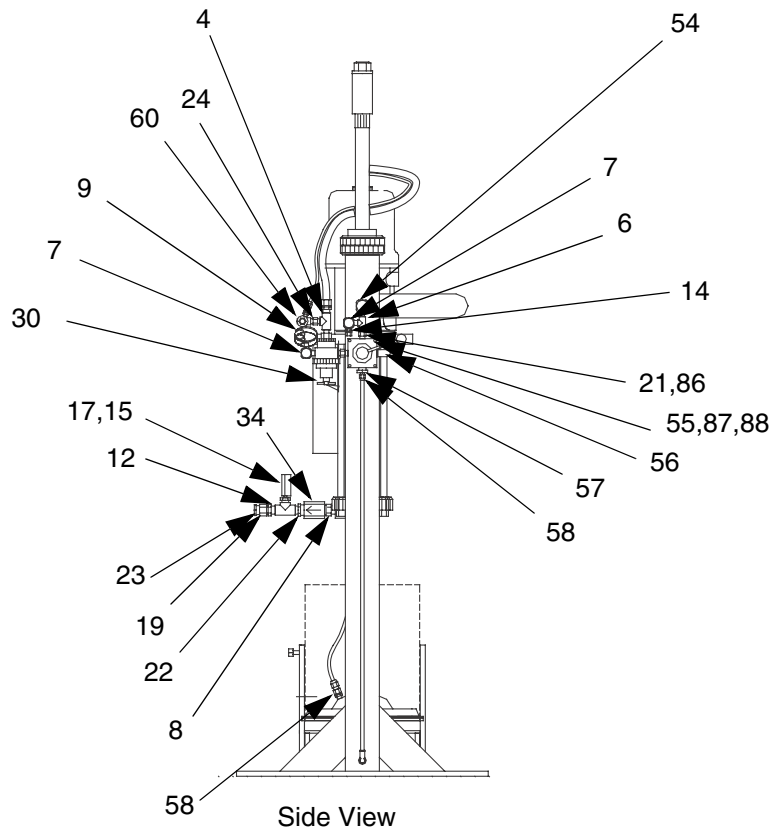
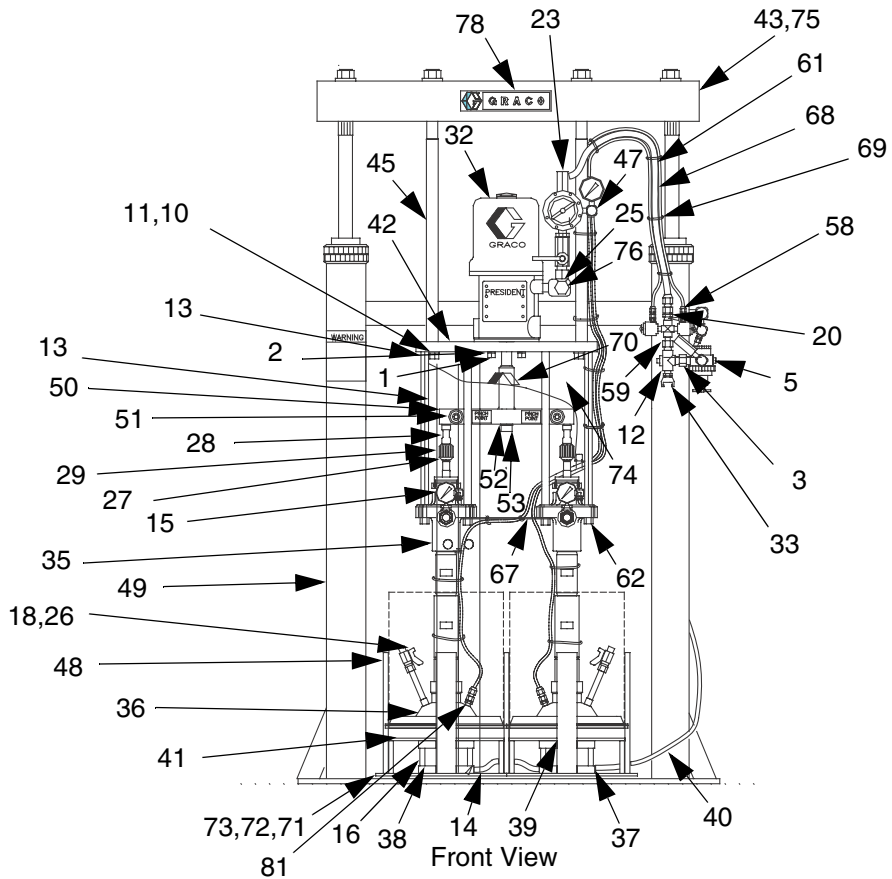

Part No. 965119

Ref. No.	Part No.	Description	Qty.	Ref. No.	Part No.	Description	Qty.
1	100060	SCREW, cap hex head	3	56	512910	MUFFLER, polyethylene 1/4 in. NPT	1
2	100018	WASHER, lock spring	3	57	113034	FITTING, tube, straight	1
3	100122	NIPPLE, close	1	58	205437	COUPLING, hose	4
4	113264	CROSS, pipe	1	59	162449	FITTING, nipple reducing	1
5	100361	PLUG, pipe	1	60	206727	VALVE, release air	2
6	108638	TEE, pipe	2	61	061132	HOSE, nylon	20
7	100840	ELBOW, street	2	62	109209	NUT, lock hex	6
8	100896	FITTING, bushing pipe	2	65▲	180233	LABEL, warning	4
9	100960	GAUGE, press air	1	66▲	513106	LABEL, warning	1
10	101533	WASHER, spring lock	6	67	624944	SPACER, pump	1
11	101535	NUT, full hex	6	68	208048	HOSE, coupled	1
12	103475	TEE, pipe	3	69	102478	STRAP, tie wiring	10
13	625077	ROD, tie 1:1 extruder	6	70	166361	EMBLEM, Graco	1
14	101959	ELBOW, cprsn male	2	71	100004	SCREW, cap hex head	4
15	102814	GAUGE, press fluid	2	72	100731	WASHER	4
16	104594	SCREW, cap	8	73	100133	WASHER, lock	4
17	100206	BUSHING, pipe	2	74	625286	SHIELD, yoke 1:2 extruder	1
18	208391	VALVE, ball	2	75	189559	CAP, end	2
19	156684	UNION, adapter	2	76	15W561	UNION, swivel 90°	1
20	156823	UNION, swivel	1	77	184119	WRENCH, packing nut	1
21	156971	NIPPLE, short	2	78	165188	EMBLEM, Graco	1
22	157191	FITTING, adapter; 1/2 npt x 3/4 npt	2	81	100451	COUPLING	2
23	158212	BUSHING	3	86	C12509	HOSE, 1/4 OD	1
25	158683	FITTING, elbow 90°	1	87	107445	SCREW, cap	2
26	100195	NIPPLE, pipe	2	88	100016	WASHER, lock	2
27	184100	NUT, coupling	2	Repair Parts			
28	184160	ROD, adapter	2	207385	Motor Seal Kit		
29	184131	COLLAR, coupling	4	222785	Throat Packing Kit (UHMW & PTFE)		
30	171937	REGULATOR, air	1	222786	Throat Packing Kit (PTFE)		
31	206995	FLUID, TSL 1 qt.	1	222784	Pump Seal Kit (Less Throat)		
32	24B229	MOTOR, Air pres	1	184101	Replacement Rod		
33	511174	FITTING, airline	1	184106	Replacement Cylinder		
34	235497	VALVE, check	2	222798	Inlet Seat Kit (Seat & O-ring)		
35	222771	PUMP, shovel	2	▲ Replacement Danger and Warning labels, tags, and cards are available at no cost.			
36	222812	PLATE, wiper, 5 gallon	2				
37	502524	FITTING, connector tube	1				
38	512004	CYLINDER, air/ 2" stroke	2				
39	512171	SCREW, machine, socket HD	2				
40	590385	TUBE, poly-flo	10				
41	623533	PLATE, pail/ram	2				
42	624909	PLATE, tie 1:1 Extrud. Checkmate	1				
43	167646	BEAM, ram	1				
45	624913	ROD, tie ram 1:1 extruder	2				
47	902413	KIT, repair	1				
48	947917	FRAME, pail locator	1				
49	257461	RAM, 55 gal, bare 3 in. pneumatic	1				
50	948617	YOKE, extruder 1:1	1				
51	513649	BEARING, cam follower	2				
52	100128	WASHER, lock	1				
53	513623	SCREW, cap socket HD	1				
54	C19391	FITTING, elbow	1				
55	513004	VALVE, directional air 1/4 in. NPT	1				

Part No. 570135

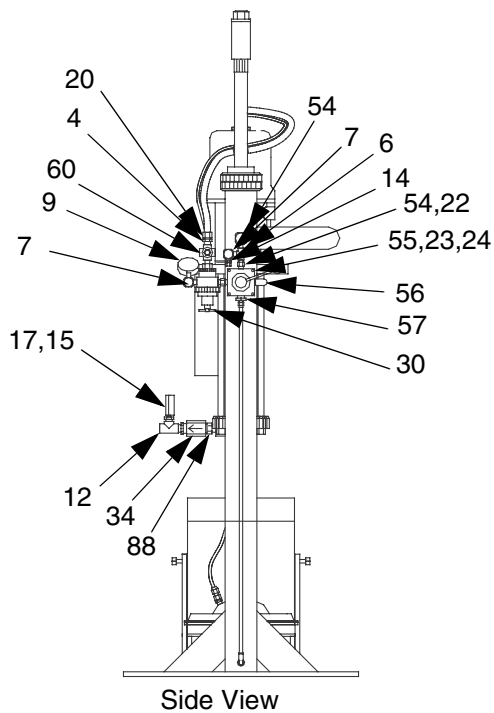
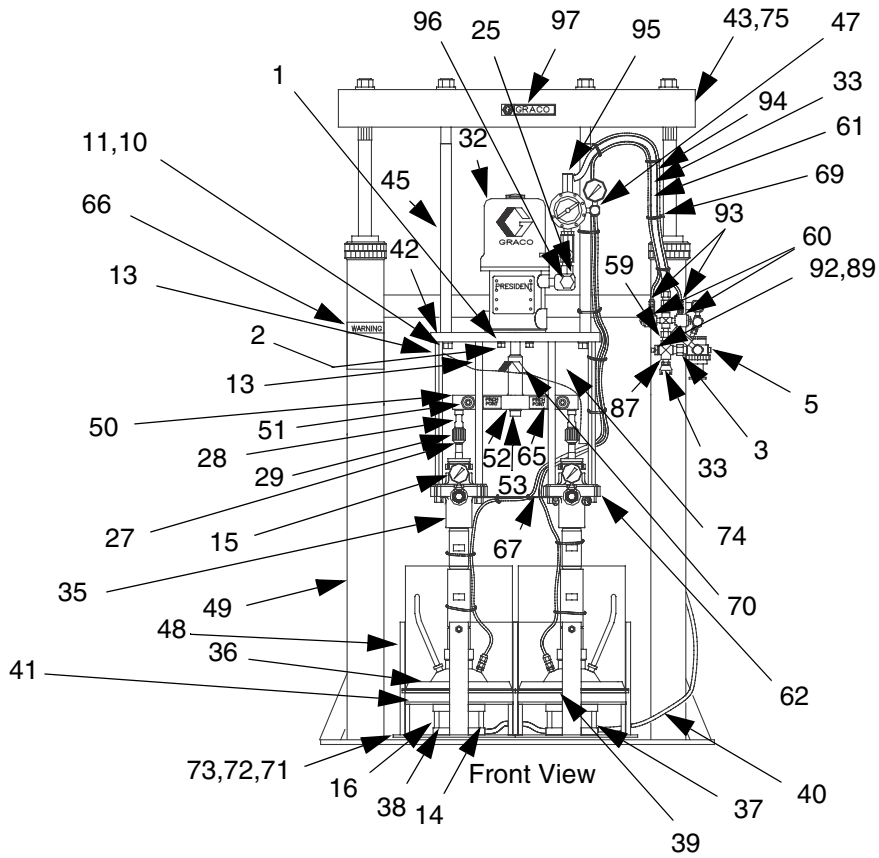

Part No. 570135

Ref. No.	Part No.	Description	Qty.	Ref. No.	Part No.	Description	Qty.
1	100060	SCREW, cap hex head	3	61	208048	HOSE, coupled	1
2	100018	WASHER, lock spring	3	62	109209	NUT, lock hex	6
3	100122	NIPPLE, close	1	65▲	180233	LABEL, warning	4
4	113264	CROSS, pipe	1	66▲	513106	LABEL, warning	1
5	100361	PLUG, pipe	1	67	624944	SPACER, pump	1
6	108638	TEE, pipe	1	69	102478	STRAP, tie wiring	10
7	100840	ELBOW, street	6	70	166361	EMBLEM, Graco	1
9	100960	GAUGE, press air	1	71	100004	SCREW, cap hex head	4
10	101533	WASHER, spring lock	6	72	100731	WASHER	4
11	101535	NUT, full hex	6	73	100133	WASHER, lock	4
12	502570	FITTING, tee 1/2 NPT	2	74	625286	SHIELD, yoke 1:1 extruder	1
13	625077	ROD, tie 1:1 extruder	2	75	189559	CAP, end	2
14	101959	ELBOW, cprsn male	2	87	C20432	FITTING, cross pipe	1
15	513432	GAUGE, press fluid SST	2	88	552049	COUPLING, 1/2 in. NPT SST	2
16	104594	SCREW, cap	8	89	100206	BUSHING, pipe	1
17	102022	BUSHING, pipe	2	92	111697	PLUG, pipe	1
20	156823	UNION, swivel	1	93	104172	FITTING, tube	2
22	C12509	HOSE, 1/4 OD	1	94	590332	TUBE, poly-flo5/32ID x 1/4OD	15
23	107445	SCREW, cap	2	95	158212	BUSHING	1
24	100016	WASHER, lock	2	96	15W561	UNION, swivel 90°	1
25	158683	FITTING, elbow 90°	1	97	165188	EMBLEM, Graco	1
27	184100	NUT, coupling	2	98	184119	WRENCH, packing nut (not shown)	1
28	184160	ROD, adapter	2				
29	184131	COLLAR, coupling	4				
30	171937	REGULATOR, air	1				
31	206995	FLUID, TSL 1 qt. (not shown)	1				
32	24B229	MOTOR, air president	1				
33	511174	FITTING, airline	2				
34	501603	VALVE, check 1/2 in. NPT SST	2				
35	222814	PUMP, shovel SST	2				
36	222909	PLATE, wiper, 5 gallon	2				
37	502524	FITTING, connector tube	1				
38	512004	CYLINDER, air/ 2 in. stroke	2				
39	512171	SCREW, machine, socket HD	2				
40	590385	TUBE, poly-flo	10				
41	623533	PLATE, pail/ram	2				
42	624909	PLATE, tie 1:1 Extrud. Checkmate	1				
43	167646	BEAM, ram	1				
45	624913	ROD, tie ram 1:1 extruder	2				
47	902413	KIT, repair	1				
48	947917	FRAME, pail locator	1				
49	257461	RAM, 55 gal, bare 3 in. pneumatic	1				
50	948617	YOKE, extruder 1:1	1				
51	513649	BEARING, cam follower	2				
52	100128	WASHER, lock	1				
53	513623	SCREW, cap socket HD	1				
54	C19391	FITTING, elbow	1				
55	513004	VALVE, directional air 1/4 in. NPT	1				
56	512910	MUFFLER, polyethylene 1/4 in. NPT	1				
57	113034	FITTING, hose, straight	1				
59	162449	FITTING, nipple reducing	1				
60	206727	VALVE, release air	2				

Repair Parts

207385	Motor Seal Kit
222785	Throat Packing Kit (UHMW & PTFE)
222786	Throat Packing Kit (PTFE)
222784	Pump Seal Kit (Less Throat)
184101	Replacement Rod
184106	Replacement Cylinder
222798	Inlet Seat Kit (Seat & O-ring)

▲ Replacement Danger and Warning labels, tags, and cards are available at no cost.

Technical Specifications

Part No. 570135

Mix ratio by volume	1:1
Pressure Ratio (Fluid/Air)	22:1
Volume Output per cycle	2.9 fl. oz.
Air Motor Diameter.	Ø4.25
Air Consumption.	10 cfm
Air Inlet	1/2 npsm(f)
Fluid Outlets	1/2 or 3/8 npt(f)
Wetted Parts	Stainless Steel, PTFE, UHMW Polyethylene
Maximum Air Working Pressure	90 psi (6.3 bar, .63 mPa)
Maximum Temperature	Ambient
Maximum Fluid Working Pressure	2000 psi (140 bar, 14.0 mPa)
Weight	500 lbs (227 kg)

Part No. 965119

Mix Ratio by Volume	1:1
Pressure Ratio (fluid/air)	22:1
Volume Output per cycle	2.9 fl. oz.
Air Motor Diameter.	Ø4.25
Air Consumption.	10 cfm
Air Inlet.	1/2 npsm(f)
Fluid Outlets	1/2 or 3/8 npt(f)
Wetted Parts	Carbon Steel, Stainless Steel, Duc- tile Iron, Zinc and Nickel Plating, PTFE, UHMW Polyethylene
Maximum Air Working Pressure	90 psi (6.3 bar, .63 mPa)
Maximum Temperature	Ambient
Maximum Fluid Working Pressure	2000 psi (140 bar, 14.0 mPa)
Weight	500 lbs (227 kg)

Mounting Footprint

Part No. 570135 and 965119

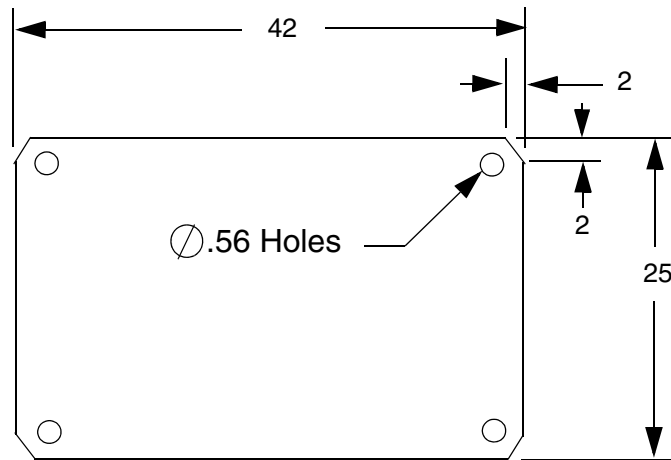

Graco Standard Warranty

Graco warrants all equipment referenced in this document which is manufactured by Graco and bearing its name to be free from defects in material and workmanship on the date of sale to the original purchaser for use. With the exception of any special, extended, or limited warranty published by Graco, Graco will, for a period of twelve months from the date of sale, repair or replace any part of the equipment determined by Graco to be defective. This warranty applies only when the equipment is installed, operated and maintained in accordance with Graco's written recommendations.

This warranty does not cover, and Graco shall not be liable for general wear and tear, or any malfunction, damage or wear caused by faulty installation, misapplication, abrasion, corrosion, inadequate or improper maintenance, negligence, accident, tampering, or substitution of non-Graco component parts. Nor shall Graco be liable for malfunction, damage or wear caused by the incompatibility of Graco equipment with structures, accessories, equipment or materials not supplied by Graco, or the improper design, manufacture, installation, operation or maintenance of structures, accessories, equipment or materials not supplied by Graco.

This warranty is conditioned upon the prepaid return of the equipment claimed to be defective to an authorized Graco distributor for verification of the claimed defect. If the claimed defect is verified, Graco will repair or replace free of charge any defective parts. The equipment will be returned to the original purchaser transportation prepaid. If inspection of the equipment does not disclose any defect in material or workmanship, repairs will be made at a reasonable charge, which charges may include the costs of parts, labor, and transportation.

THIS WARRANTY IS EXCLUSIVE, AND IS IN LIEU OF ANY OTHER WARRANTIES, EXPRESS OR IMPLIED, INCLUDING BUT NOT LIMITED TO WARRANTY OF MERCHANTABILITY OR WARRANTY OF FITNESS FOR A PARTICULAR PURPOSE.

Graco's sole obligation and buyer's sole remedy for any breach of warranty shall be as set forth above. The buyer agrees that no other remedy (including, but not limited to, incidental or consequential damages for lost profits, lost sales, injury to person or property, or any other incidental or consequential loss) shall be available. Any action for breach of warranty must be brought within two (2) years of the date of sale.

GRACO MAKES NO WARRANTY, AND DISCLAIMS ALL IMPLIED WARRANTIES OF MERCHANTABILITY AND FITNESS FOR A PARTICULAR PURPOSE, IN CONNECTION WITH ACCESSORIES, EQUIPMENT, MATERIALS OR COMPONENTS SOLD BUT NOT MANUFACTURED BY GRACO. These items sold, but not manufactured by Graco (such as electric motors, switches, hose, etc.), are subject to the warranty, if any, of their manufacturer. Graco will provide purchaser with reasonable assistance in making any claim for breach of these warranties.

In no event will Graco be liable for indirect, incidental, special or consequential damages resulting from Graco supplying equipment hereunder, or the furnishing, performance, or use of any products or other goods sold hereto, whether due to a breach of contract, breach of warranty, the negligence of Graco, or otherwise.

FOR GRACO CANADA CUSTOMERS

The Parties acknowledge that they have required that the present document, as well as all documents, notices and legal proceedings entered into, given or instituted pursuant hereto or relating directly or indirectly hereto, be drawn up in English. Les parties reconnaissent avoir convenu que la rédaction du présente document sera en Anglais, ainsi que tous documents, avis et procédures judiciaires exécutés, donnés ou intentés, à la suite de ou en rapport, directement ou indirectement, avec les procédures concernées.

Graco Information

For the latest information about Graco products, visit www.graco.com.

TO PLACE AN ORDER, contact your Graco distributor or call to identify the nearest distributor.
Phone: 612-623-6921 or Toll Free: 1-800-328-0211 Fax: 612-378-3505

*All written and visual data contained in this document reflects the latest product information available at the time of publication.
Graco reserves the right to make changes at any time without notice.*

Original instructions. This manual contains English. MM 310726

Graco Headquarters: Minneapolis
International Offices: Belgium, China, Japan, Korea
GRACO INC. P.O. BOX 1441 MINNEAPOLIS, MN 55440-1441

Copyright 2003, Graco Inc. is registered to ISO 9001
www.graco.com
Revised 10/2010