

BINKS®

Binks Model 95A Automatic Conventional Air Spray Gun and Binks Model 95AV (For Ceramic Coatings) Conventional Air Spray Gun

95A Gun 6469-XXXX-X
95AV Gun 6487-XXXX-X



STANDARD SET-UPS AVAILABLE (SEE PG. 9).
OPTIONAL SET-UPS PLEASE ORDER SEPARATELY
(SEE PGS. 8 & 9).

AUTOMATIC AIR SPRAY GUN WITH STAINLESS STEEL FLUID INLET

MODEL 95A AND 95AV SPRAY GUN

The Binks Model 95A Automatic Spray Gun is a conventional style air spray gun. It incorporates all stainless steel fluid inlet, fluid nozzle, and fluid needle for spraying a wide variety of conventional and waterborne coatings.

Model 95AV incorporates tungsten carbide fluid nozzles used in ceramic and abrasive coating applications. It is also pneumatically activated for application with reciprocating, rotary, spindle machines, and in stationary gun set-ups.

Exceptionally rugged in construction, the Binks Model 95A and 95AV guns are built to stand up under hard, continuous use. However, like any other fine precision instrument, their most efficient operation depends on a knowledge of their construction, operation, and maintenance.

Properly handled and cared for, these guns will produce beautiful, uniform finishing results long after other spray guns have worn out.

Replaces Part Sheet 77-2641R-13	Part Sheet 77-2641R-14
---------------------------------------	------------------------------

In this part sheet, the words **WARNING**, **CAUTION** and **NOTE** are used to emphasize important safety information as follows:

⚠ WARNING
 Hazards or unsafe practices which could result in severe personal injury, death or substantial property damage.

⚠ CAUTION
 Hazards or unsafe practices which could result in minor personal injury, product or property damage.

NOTE
 Important installation, operation or maintenance information.

⚠ WARNING

Read the following warnings before using this equipment.



READ THE MANUAL
 Before operating finishing equipment, read and understand all safety, operation and maintenance information provided in the operation manual.



WEAR SAFETY GLASSES
 Failure to wear safety glasses with side shields could result in serious eye injury or blindness.

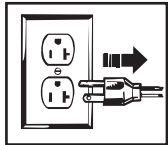

DE-ENERGIZE, DISCONNECT AND LOCK OUT ALL POWER SOURCES DURING MAINTENANCE
 Failure to De-energize, disconnect and lock out all power supplies before performing equipment maintenance could cause serious injury or death.



OPERATOR TRAINING
 All personnel must be trained before operating finishing equipment.



EQUIPMENT MISUSE HAZARD
 Equipment misuse can cause the equipment to rupture, malfunction, or start unexpectedly and result in serious injury.

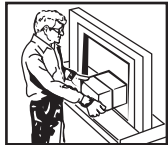

KEEP EQUIPMENT GUARDS IN PLACE
 Do not operate the equipment if the safety devices have been removed.

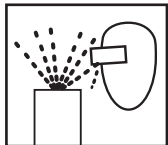

PROJECTILE HAZARD
 You may be injured by venting liquids or gases that are released under pressure, or flying debris.



PINCH POINT HAZARD
 Moving parts can crush and cut. Pinch points are basically any areas where there are moving parts.



AUTOMATIC EQUIPMENT
 Automatic equipment may start suddenly without warning.



INSPECT THE EQUIPMENT DAILY
 Inspect the equipment for worn or broken parts on a daily basis. Do not operate the equipment if you are uncertain about its condition.



NEVER MODIFY THE EQUIPMENT
 Do not modify the equipment unless the manufacturer provides written approval.



KNOW WHERE AND HOW TO SHUT OFF THE EQUIPMENT IN CASE OF AN EMERGENCY



PRESSURE RELIEF PROCEDURE
 Always follow the pressure relief procedure in the equipment instruction manual.



NOISE HAZARD
 You may be injured by loud noise. Hearing protection may be required when using this equipment.



STATIC CHARGE
 Fluid may develop a static charge that must be dissipated through proper grounding of the equipment, objects to be sprayed and all other electrically conductive objects in the dispensing area. Improper grounding or sparks can cause a hazardous condition and result in fire, explosion or electric shock and other serious injury.



FIRE AND EXPLOSION HAZARD
 Never use 1,1,1-trichloroethane, methylene chloride, other halogenated hydrocarbon solvents or fluids containing such solvents in equipment with aluminum wetted parts. Such use could result in a serious chemical reaction, with the possibility of explosion. Consult your fluid suppliers to ensure that the fluids being used are compatible with aluminum parts.



PROP 65 WARNING
 WARNING: This product contains chemicals known to the State of California to cause cancer and birth defects or other reproductive harm.

IT IS THE RESPONSIBILITY OF THE EMPLOYER TO PROVIDE THIS INFORMATION TO THE OPERATOR OF THE EQUIPMENT.

FOR FURTHER SAFETY INFORMATION REGARDING BINKS AND DEVILBISS EQUIPMENT, SEE THE GENERAL EQUIPMENT SAFETY BOOKLET (77-5300).

Binks Models 95A and 95AV AUTOMATIC CONVENTIONAL SPRAY GUNS
Typical Arrangement Diagram and Hook-up for
Combined Fan and Atomizing Air

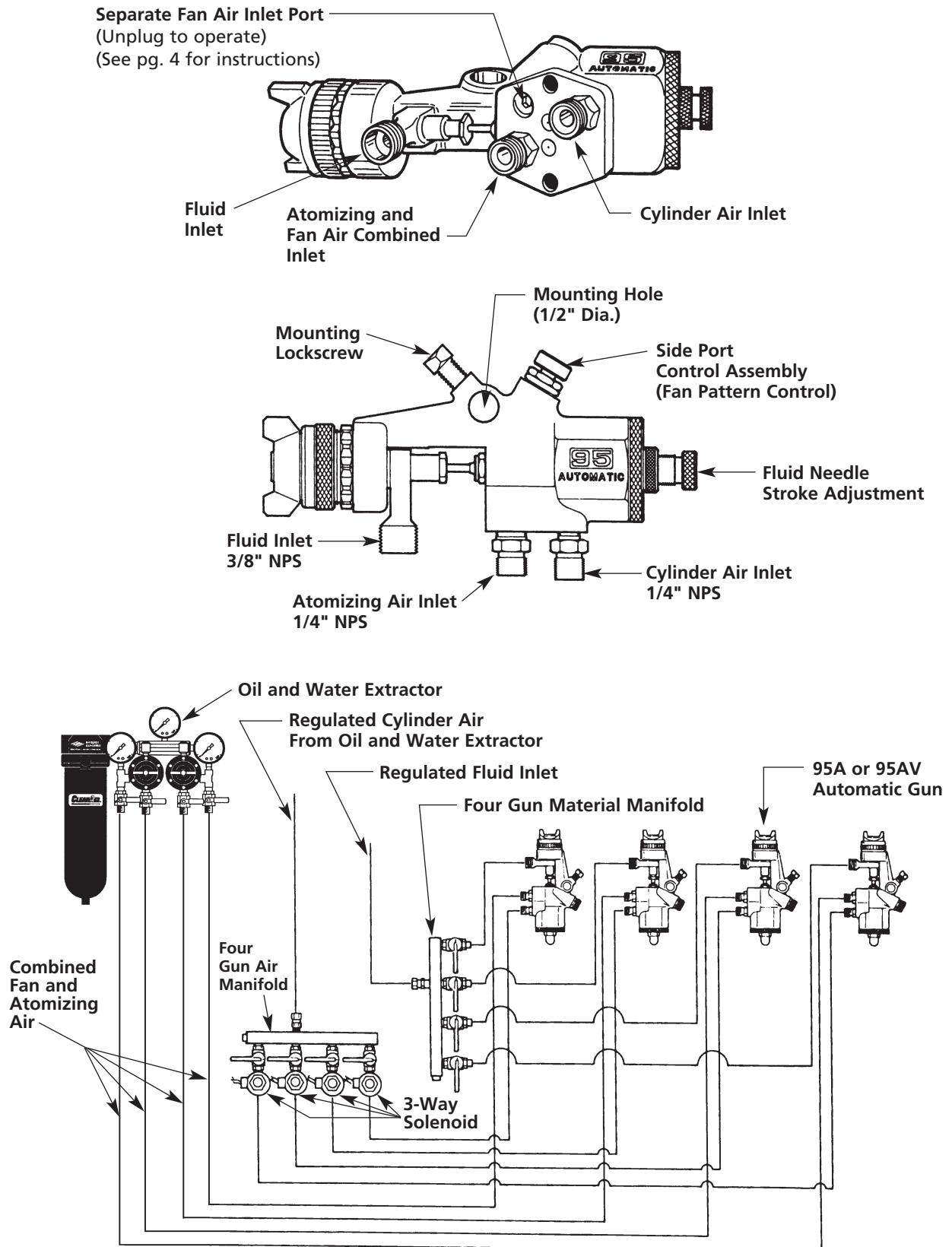

For some applications each gun may require individually regulated fluid and air inlet lines.

Binks Models 95A and 95AV AUTOMATIC SPRAY GUNS
Typical Arrangement Diagram and Hook-up for
Separate Fan and Atomizing Air
 (See Page 5 for Internal Modifications to Gun)

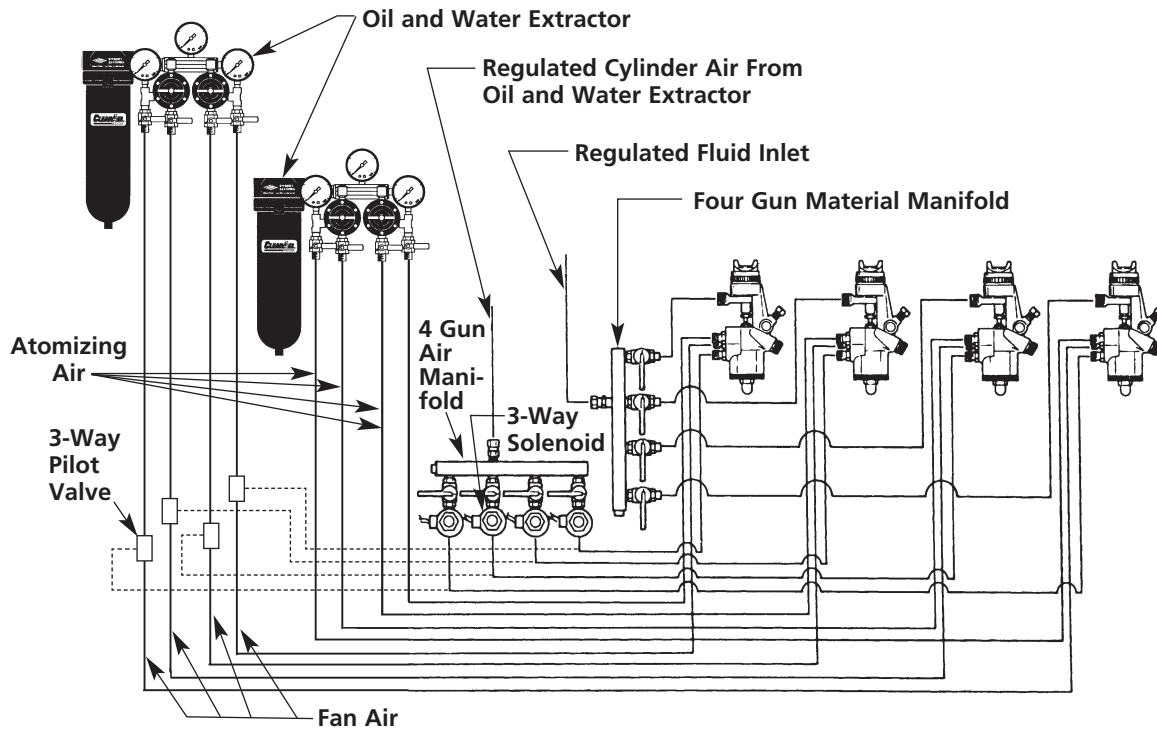
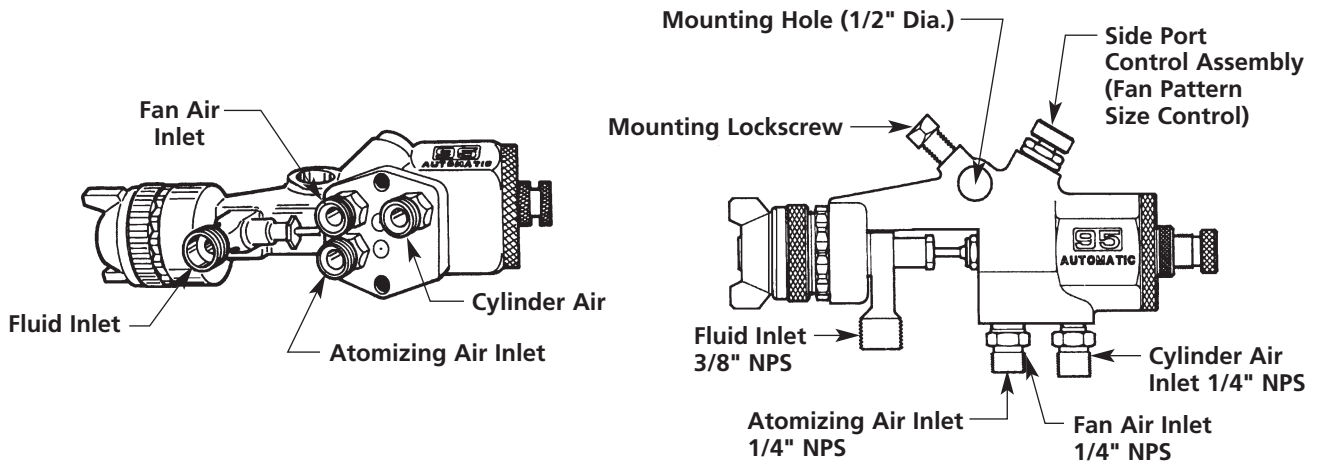

For some applications each gun may require individually regulated fluid and air inlet lines.

GENERAL NOTES

1. Have at least 55-60 P.S.I. air pressure for cylinder's operating air. (Maximum 90 PSIG)
2. To reduce overspray and obtain maximum efficiency, always spray with lowest possible fluid/air pressure that produces an acceptable spray pattern.
3. The air line from gun to 3-way valve should be as short as possible for rapid operation.
4. All air used in the gun should be dirt and moisture free. (This is accomplished by using an oil and water extractor).
5. Shut off all fluid and air lines to gun if gun is to stand idle for any length of time. (This is to prevent "build up" or accumulation of minute leaks in the system and turning on the gun).

**TO CHANGE FROM COMBINED FAN AND ATOMIZING AIR
TO SEPARATE FAN AND ATOMIZING AIR**

1. Unscrew end cap (28) and remove material needle (22) and attached parts (23, 24, 25) (see assembly drawing page 10).
2. Remove piston assembly (18) by injecting low pressure air into cylinder air port (A).

3. With 5/32" allen wrench, remove plug (16) from hole (B) on inside of cylinder.
4. Insert set screw (46) into position as shown in side cut-away. (Set screw is packaged loose.)
5. Re-install plug (16).
6. Re-install piston (20), 2 springs (26, 27), material needle (22) and end cap (28). (See assembly drawing page 10).
7. Remove plug (43) from the fan air port (C).
8. Install fitting (32) into port (C). (Fitting is packaged loose.)

⚠ WARNING
Use of excessive pressure will cause piston to exit gun body at high velocity, possibly resulting in personal injury or damage to spray gun components. When removing the piston, aim back of gun in a safe direction and do not use excessive air pressure.

NOTE
D.M. Nipple (32) shipped loose in a separate bag.

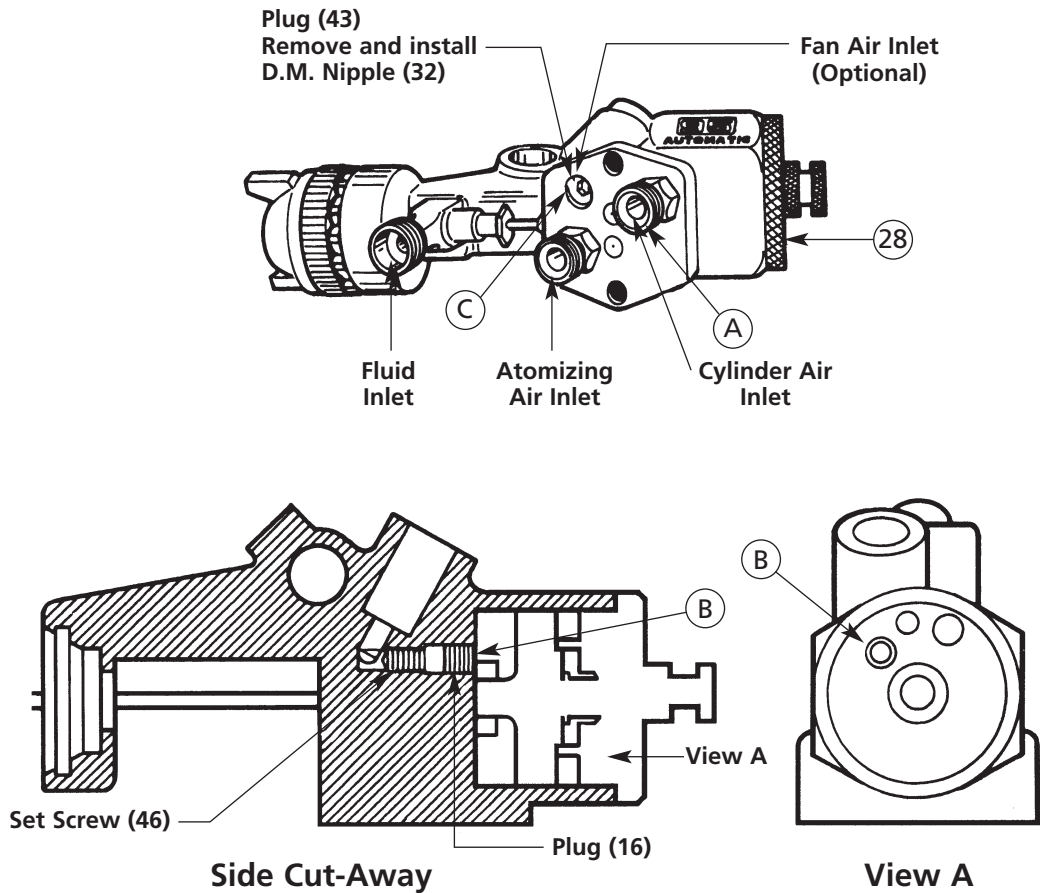

NOTE
Set screw (46) shipped loose in a separate bag.

SETUP FOR SPRAYING

CONNECTING GUN TO MATERIAL HOSE

Gun should be connected by a suitable length of 3/8" diameter material hose fitted with a connector with a 3/8" NPS(f) nut at gun end. 1/4" diameter hose is recommended for use with low viscosity materials. (Fluid hoses of different composition are available for special fluids. See Binks hose catalog for hose selection.)

CONNECTING GUN TO ATOMIZING AIR

Gun should be connected by a suitable length of 5/16"

or 3/8" diameter air hose fitted with a connector and a 1/4" NPS(f) nut at gun end.

CONNECTING GUN TO CYLINDER AIR

Gun should be connected with 3/16" I.D. or 1/8" I.D. air hose of shortest length possible with 1/4" NPS(f) connector. Cylinder air must be connected to a 3-way manual air valve or 3-way solenoid valve to operate properly.

OPERATING THE MODEL 95A AUTOMATIC SPRAY GUN

CONTROLLING THE MATERIAL FLOW

When fed from a pressure supply, an increase in the material pressure will increase the rate of flow. Correct fluid nozzle size insures correct material flow rate. If necessary, fluid flow can also be adjusted by adjusting the amount of needle travel. This is done by loosening lock nut (29) and adjusting control knob (30) until the correct needle travel is achieved.

ADJUSTING AIR AND FLUID TIMING

A 1/16" gap between the air piston assembly (18) and needle body (24) should be maintained (see figure 1). This will create needle motion that will allow adequate air flow before the fluid starts flowing. The gap may be adjusted by partially removing the material needle (22),

screwing the needle (22) either in or out of the needle body (24) and locking it back into the gun while being sure to check the clearance between the air valve piston (18) and the needle body (24).

ADJUSTING THE SPRAY PATTERN

The width of the spray pattern is controlled by the side port control assembly (7). (See page 10). Turning this control clockwise until it is closed will give a round spray, turning it counterclockwise will widen the spray into a fan shape. The fan spray can be turned anywhere through 360° by positioning the air cap assembly (1) relative to the gun. To effect this, loosen air cap assembly, position nozzle, then, re-tighten air cap assembly.

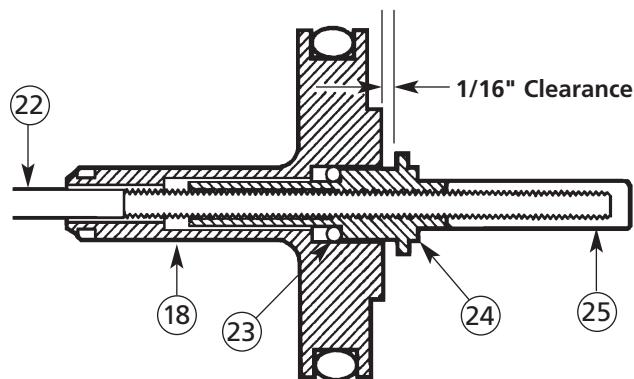

Figure 1

FLUID NEEDLE ADJUSTMENT DIAGRAM

MAINTENANCE

LUBRICATION

Monthly: Remove piston assembly (18) and lubricate the air cylinder chamber and needle valve spring with a coating of Gunners Mate (47). Also, lubricate side port control assembly (7) with oil.

⚠ CAUTION

Never use lubricants containing silicone since these lubricants can cause finish defects. Binks Gunners Mate (47) is recommended.

REMOVAL OF PISTON

To remove the piston, first unscrew the end cap (28), remove 2 springs (26 & 27) and pull out the material needle (22) and attached parts (23, 24, & 25). Remove the piston by applying a few pounds of air pressure to the cylinder air inlet. This air pressure will cause the piston to pop out.

⚠ WARNING

Excessive air pressure applied to the piston during removal may cause the piston to exit at a high velocity, resulting in personal injury. When removing the piston, aim back of gun in a safe direction and do not use excessive pressure.

TO REPLACE NEEDLE SEAL AND GLAND ADAPTER IN FLUID INLET

Remove end cap (28), springs (26 & 27) and assemble material needle (22) and attached parts (23, 24, & 25). Proceed to the front of the gun and remove air cap assembly (1) and fluid nozzle (2). Then, using wrench (44), unscrew head insert (4) and remove fluid inlet (33 or 34). Unscrew packing nut (39) and remove spring (38) and seal backup (37). Using a No. 10 x 1-1/4" coarse thread wood screw (Binks part no. 20-6536) or small sheet metal screw, remove the needle seal (36) and gland adapter (35). Replace gland adapter (35) and needle seal (36). Reinsert seal backup (37), spring (38) and screw on packing nut (39) a couple of turns so it fits loosely by hand. Reassemble fluid inlet (34) to gun body (5) with head insert (4). Tighten head insert using wrench (44). Reassemble fluid nozzle (2) and air cap assembly (1). Reinsert material needle (22) and attached parts (23, 24 & 25), springs (26 & 27) and screw on end cap (28). Finally, tighten packing nut (39) until it bottoms out on fluid inlet (34).

CLEANING

In certain states it is now against the law to spray solvents containing Volatile Organic Compounds (VOCs) into the atmosphere when cleaning a spray gun.

In order to comply with these new air quality laws Binks recommends one of the following two methods to clean your spray finishing equipment:

1. Spray solvent through the gun into a closed system. An enclosed unit, or spray gun cleaning station, condenses solvent vapors back into liquid form which prevents escape of VOCs into the atmosphere.
2. Place spray gun in a washer type container. This system must totally enclose the spray gun, cups, nozzles, and other parts during washing, rinsing, and draining

cycles. This type of unit must be able to flush solvent through the gun without releasing any VOC vapors into the atmosphere. Additionally, open containers for storage or disposal of solvent, or solvent-containing cloth or paper, used for surface preparation and clean-up may not be used. Containers shall be non-absorbent.

To clean the gun, flush the fluid lines with solvent and blow air through the air lines to make sure all the air passages are dry.

⚠ CAUTION

Never completely submerge the gun in solvent as this will dissolve the lubricating oil and dry out the seals.

TROUBLESHOOTING

FAULTY SPRAY

A faulty spray may be caused by improper cleaning, dried materials around the fluid nozzle tip or in the air cap. Soak these parts in thinners that will soften the dried material and remove with a brush or cloth.

⚠ CAUTION

Never use metal instruments to clean the air or fluid nozzles. These parts are carefully machined and any damage to them will cause faulty spray.

If either the air cap assembly (1) or fluid nozzle (2) are damaged, these parts must be replaced before perfect spray can be obtained.

INTERMITTENT SPRAY

If the spray flutters, it is caused by one of the following faults:

1. Insufficient material available. Check supply and replenish if necessary.
2. Loose fluid nozzle (2). Tighten, but without using undue force.
3. Leakage at gland adapter (35) and needle seal (36). Tighten packing nut (39) if loose, and replace gland adapter and needle seal if necessary.
4. Fluid connection insufficiently tight or dirt on cone faces of connection. Correct as necessary.
5. Leaking cylinder air and/or inadequate pressure.

**NOZZLE, AIR CAP, AND NEEDLE SELECTION CHART
FOR 95A and 95AV AUTOMATIC GUNS**

TYPE OF FLUID VISCOSITY TO BE SPRAYED	FLUID NOZZLE x AIR CAP	AIR CAP TYPE	CFM AT *			MAX. PATTERN AT 8"	FLUID NEEDLE	
			30 PSI	50 PSI	70 PSI			
VERY THIN VISCOSITY	63SS x 63P	PE	4.5	7.5	10.0	5.0"	763	
14-16 Seconds – No. 2 ZAHN Wash Primers Dyes Stains Solvents Water Inks	63ASS x 63P	PE	5.1	8.7	12.2	11.0"	763A	
	63BSS x 63PB	PE	9.0	14.3	20.0	14.0"	763A	
	66SS x 66SD	SE	7.9	12.1		10.5"	765	
	66SS x 66SK	SE	11.0	15.2	19.5	13.0"	765	
	63B5SS x 200●	PI	3.1	5.2	6.4	12.0"	763A	
	63BSS x 21MD-3	PE	11.6	16.6	22.2	16.0"	763A	
	THIN VISCOSITY	63ASS x 63P	PE	5.1	8.7	12.2	11.0"	763A
16-20 Seconds – No. 2 ZAHN Sealers Lacquers Primers Inks Zinc Chromates Acrylics Lubricants	66SS x 66SK	SE	11.0	15.2	19.5	13.0"	765	
	63BSS x 200●	PI	3.1	5.2	6.4	12.0"	763A	
	63BSS x 21MD-3	PE	11.6	16.6	22.2	16.0"	763A	
	MEDIUM VISCOSITY	63BSS x 63PB	PE	9.0	14.3	20.0	14.0"	763A
19-30 Seconds – No. 2 ZAHN Synthetic Enamels Varnishes Shellacs Fillers Primers Epoxies Urethanes Lubricants Wax Emulsions	63CSS x 63PR	PE	9.5	15.5	19.5	18.0"	763A	
	65SS x 63PR	PE	11.0	16.5	22.0	15.0"	765	
	66SS x 66SD	SE	7.9	12.1		11.0"	765	
	66SS x 66SK	SE	11.0	15.2	19.5	13.0"	765	
	63CSS x 200●	PI	3.1	5.2	6.4	12.0"	763A	
	63BSS x 21MD-3	PE	11.6	16.6	22.2	16.0"	763A	
	66SS x 21MD-2	PE	12.5	18.3	24.4	13.0"	765	
	HEAVY (CREAM-LIKE) VISCOSITY	67SS x 206	PI	6.0	9.5	13.0	15.0"	767
	Over 28 Seconds – No. 4 FORD House Paint Wall Paint (Oil, Latex) Block Sealers Mill Whites Vinyls Acrylics Epoxies	68SS x 201	PI	4.6	6.8	9.1	11.0"	768
68SS x 101■		PI	4.6	6.8	9.1	11.0"	768	
66SS x 63PB		PE	9.0	14.3	20.0	14.0"	765	
67SS x 67PB		PE	9.5	14.9	19.5	12.0"	767	
68SS x 68PB		PE	9.5	14.1	19.1	12.0"	768	
67SS x 21MD-2		PE	12.5	18.3	24.4	13.0"	765	
VERY HEAVY VISCOSITY		68SS x 206	PI	6.2	9.8	13.2	15.0"	768
Unaggregated Block Fillers Textured Coatings Fire Retardants Road Marking Paint Bitumastics Cellular Plastisols		68SS x 68PB	PE	9.5	14.1	19.1	12.0"	768
	59ASS x 244●	PI	7.8	11.5	15.2	12.0"	759	
	59BSS x 250●	PI	7.8	11.0	14.7	RND	759	
	59BSS x 252●	PI	7.8	11.5	15.2	12.0"	759	
	ADHESIVES	63CSS x 63PB	PE	9.0	14.3	20.0	14.0"	763A
Waterbase White Vinyl Glue Solvent Base Neoprenes (Contact Cements)	66SS x 63PR	PE	9.5	15.5	19.5	15.0"	765	
	67SS x 67PB	PE	9.5	14.1	19.1	12.0"	767	
	63SS x 66SD	PE	7.9	12.1	16.2	4.0"	763	
	63ASS x 66SD	PE	7.9	12.1	16.2	7.0"	763A	
	66SS x 66SD-3	PE	10.4	15.4	20.4	9.0"	765	
	CERAMICS & SIMILAR ABRASIVE MATERIAL	63CVT x 66PH	PE	11.5	16.4	22.0	13.0"	763VT
Glazes, Engobes Porcelain Enamel	67VT x 21MD-2	PE	12.5	18.3	24.4	13.0"	767VT	
	67VT x 67PD	PE	10.0	15.0	20.0	15.0"	767VT	
	68VT X 68PB	PE	9.5	14.1	19.1	12.0"	768VT	

*Be certain your air supply is sufficient to operate nozzles selected.

†PE, Pressure feed, external. SE, Siphon feed, external.

PI, Pressure feed, internal. VT, Tungsten Carbide Fluid Nozzles. ■ Tungsten Carbide Air. ● Nitralloy Air Nozzle.

Nozzle No.	59ASS	59BSS	59CSS	63ASS	63BSS	63CSS	65SS	66SS	67SS	68SS
Orifice Size	.171	.218	.281	.040	.046	.052	.059	.070	.086	.110

**NOZZLE, AIR CAP, AND NEEDLE SELECTION CHART
FOR 95A and 95AV AUTOMATIC GUNS (cont.)**

TYPE OF FLUID TO BE SPRAYED	FLUID NOZZLE x AIR CAP	AIR CAP TYPE†	CFM AT *			MAX. PATTERN AT 8"	FLUID NEEDLE
			30 PSI	50 PSI	70 PSI		
CONCRETE CURING COMPOUNDS	63SS x 200●	PI	3.1	5.2	6.4	15.0"	765
	67SS x 206●	PI	6.0	9.5	13.0	18.0"	767
	68SS x 206●	PI	6.2	9.8	13.2	20.0"	768
MULTICOLOR PAINTS	66SS x 200●	PI	3.1	5.2		12.0"	765
	67SS x 206●	PI	6.0	9.5		15.0"	767
PTFE/PVA (NON-STICK COATINGS)	63ASS x 63PB	PE	9.0	14.3	20.0	10.0"	763A
	63BSS x 63PR	PE	9.5	15.5	19.5	15.0"	763A
	66SS x 66SD	SE	7.9	12.1		7.0"	765
HAMMERS	63CSS x 63PB	PE	9.0	14.3		14.0"	763A
	66SS x 63PB	PE	9.0	14.3		14.0"	765
	66SS x 66SD	SE	7.9	12.1		7.0"	765
WRINKLE ENAMELS	63CSS x 63PB	PE	9.0	14.3	20.0	10.0"	763A
	66SS x 63PB	PE	9.0	14.3	20.0	10.0"	765
ZINC RICH COATINGS	67VT x 67PB	PE	9.5	14.1	19.1	12.0"	767VT

*Be certain your air supply is sufficient to operate nozzles selected.

†PE, Pressure feed, external. SE, Siphon feed, external.

PI, Pressure feed, internal. VT, Tungsten Carbide Fluid Nozzles. ■ Tungsten Carbide Air. ● Nitralloy Air Nozzle.

Nozzle No.	59ASS	59BSS	59CSS	63ASS	63BSS	63CSS	65SS	66SS	67SS	68SS
Orifice Size	.171	.218	.281	.040	.046	.052	.059	.070	.086	.110

**STANDARD PART NUMBERS for 95A and 95AV GUNS
with Fluid Nozzles, Air Caps and Needles Included.**

95A GUN

6469-1900-795A GUN 62SS-63PB
 6469-2500-795A GUN 63ASS-63PB
 6469-2800-795A GUN 63BSS-63PB
 6469-3100-795A GUN 63CSS-63PB
 6469-4307-995A GUN 66SS-66SD
 6469-4308-895A GUN 66SS-66SK
 6469-5111-595A GUN 68SS-68PB
 6469-8219-195A GUN 59CSS-262

95AV GUN

6487-4909-995AV GUN 67VT-67PD
 6487-5211-595AV GUN 68VT-68PB

Binks Model 95A, 95AV Automatic Air Spray Gun Assembly Drawing

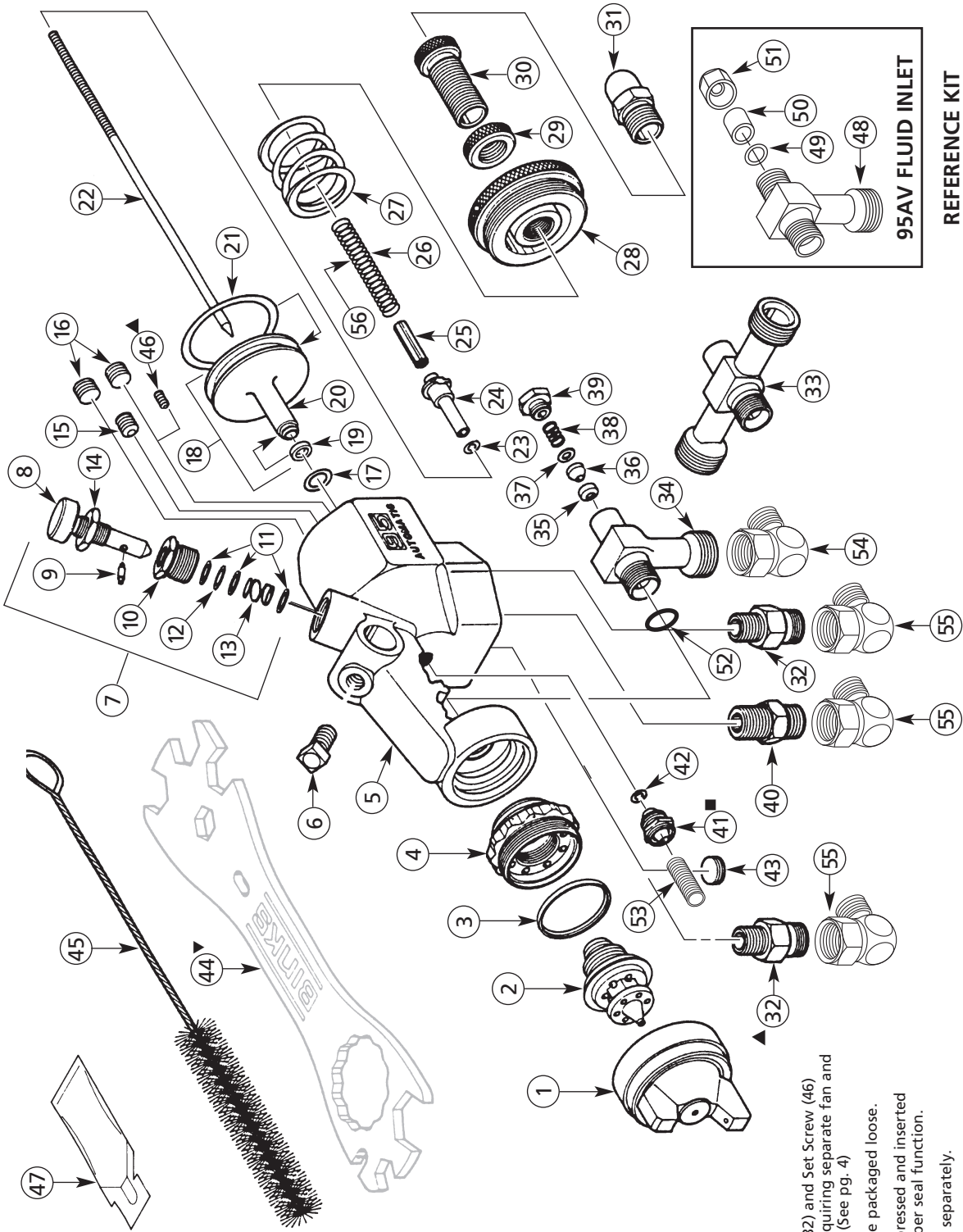

95AV FLUID INLET
REFERENCE KIT
54-4511

- ▲ Double Male Nipple (32) and Set Screw (46) are for installations requiring separate fan and atomizing air control. (See pg. 4)
- Items 31, 32 and 46 are packaged loose.
- Item 42 must be compressed and inserted inside Item 41 for proper seal function.
- ▼ Accessory item. Order separately.

PARTS LIST

(When ordering, please specify Part No.)

ITEM NO.	PART NO.	DESCRIPTION	QTY.	ITEM NO.	PART NO.	DESCRIPTION	QTY.
1	*	AIR CAP ASSEMBLY	1	32	71-28	DOUBLE MALE NIPPLE 1/8 NPT x 1/4 NPS	2
2	*	FLUID NOZZLE	1	33	54-4208	FLUID INLET Recirculating (Optional) ..	1
3	54-918●▲	SEALING RING	1	34	54-4210	FLUID INLET (95A Gun)	1
4	54-4215	HEAD INSERT	1	35	54-4264●▲	GLAND ADAPTER (95A Gun)	1
5	54-4206	95A GUN BODY ASSEMBLY	1	36	54-4265●▲	NEEDLE SEAL (95A Gun)	1
6	20-1359	SQ. HD. BOLT 5/16-18 X 3/4	1	37	54-4266●▲	SEAL BACKUP (95A Gun)	1
7	54-3720	SIDE PORT CONTROL ASSEMBLY	1	38	54-4267●▲	SPRING (95A Gun)	1
8	54-3721	CONTROL SPINDLE	1	39	54-4263●▲	PACKING NUT (95A Gun)	1
9	31-258	RETAINING PIN	1	40	57-13	DOUBLE MALE NIPPLE 1/4 NPT x 1/4 NPS	1
10	31-256	STUFFING BOX	1	41	54-3716	AIR VALVE GLAND ASSEMBLY	1
11	31-259	INNER WASHER	3	42	20-3859▲	O-RING	1
12	20-3620▲	O-RING	1	43	54-3986■	PLUG 1/8-27 NPT	1
13	31-241	CONTROL SPRING	1	44	54-4213▼	WRENCH (Optional)	1
14	54-4269	JAM NUT	1	45	82-469	GUN BRUSH	1
15	54-3987■	PLUG	1	46	20-2141	SET SCREW 1/4"-20 UNC	1
16	54-3988■	PLUG 1/16" NPT	2	47	54-3871	GUNNERS MATE	1
17	20-5286▲	O-RING	1	48	54-4568★	FLUID INLET (95AV Gun)	1
18	54-3706	PISTON ASSEMBLY	1	49	20-2227●▲★	O-RING (95AV Gun)	1
19	54-3729◆▲	SEAL	1	50	54-4531●▲★	SPACER (95AV Gun)	1
20	54-3722◆	PISTON	1	51	54-4542★	NUT ASSEMBLY (95AV Gun)	1
21	20-4511▲	O-RING	1	52	54-3592●	FLUID INLET SEAL	1
22	*	NEEDLE	1	53	54-4270	NEEDLE COVER	1
23	20-3515▲	O-RING	1	54	73-24	90° S.S. CONNECTION (Optional)	1
24	54-3713	NEEDLE BODY	1	55	73-12	90° CONNECTION (Optional)	3
25	54-3709	NEEDLE LOCKING NUT	1	56	54-3719	SPRING Heavy Duty (Optional)	1
26	54-3719	SPRING Needle Return	1				
27	54-1876	SPRING Piston Return	1				
28	54-3708	END CAP	1				
29	54-3732	LOCKNUT	1				
30	54-3731	CONTROL KNOB	1				
31	54-3715	STOP SCREW	1				

* See Air Cap, Fluid Nozzle, and Needle Selection Chart on pgs. 6-7.
 ● Part of Repair Kit 54-4225. ▲ Part of Repair Kit 54-3579.
 ■ Part of Gun Body Assembly, item 5.
 ◆ Part of item 18. Also available separately.
 ▼ Accessory item. Order separately.
 ★ Included in 54-4511 kit for vitreous set-up.

OPTIONAL NOZZLE SET-UPS
 (When ordering, please specify Part No.)

ITEM NO.	PART NO.	DESCRIPTION	QTY.
60	54-1584	RETAINING RING	1
61	54-1583	NOZZLE TIP BASE ASSEMBLY	1
62	54-2065	RING	1
63	659	NEEDLE ASSEMBLY	1

INTERNAL MIX HEAVY MATERIAL NOZZLES (OPTIONAL)

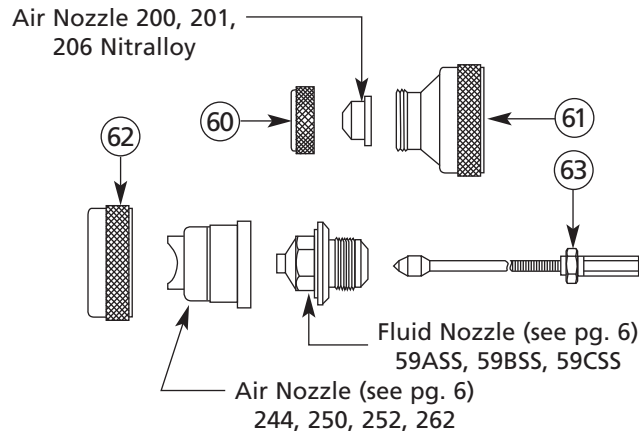

GUN DIMENSIONS

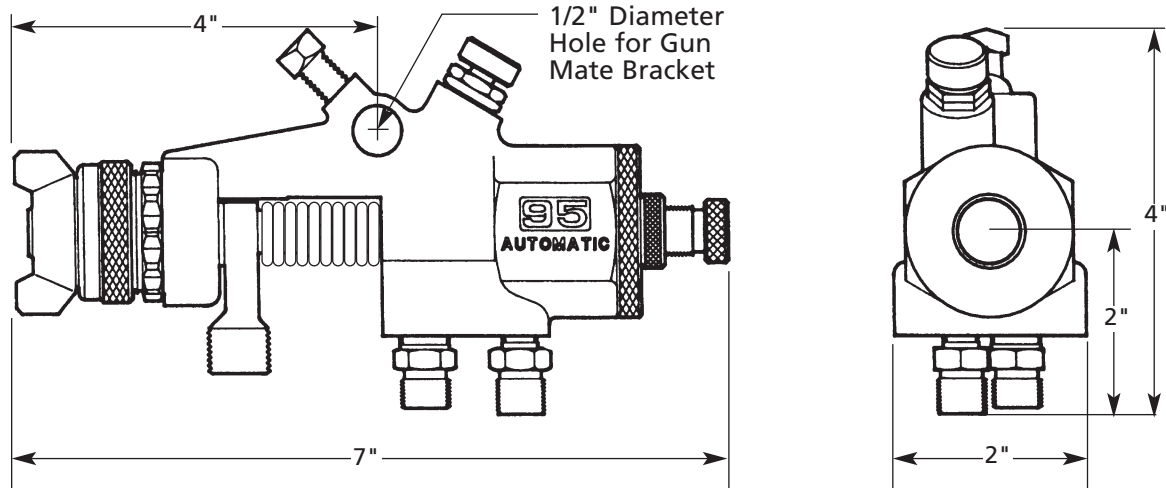

Approximate Weight 1.2 lbs.

ACCESSORIES (Optional)

MOUNTING BRACKETS

Use for automatic guns. Adjustable to any position. 18" bracket arm. 1" diameter bracket clamp hole for attachment to facility hardware.

54-380 Steel bracket for automatic guns. Shipping weight: 5 lbs. Part Sheet 1185.

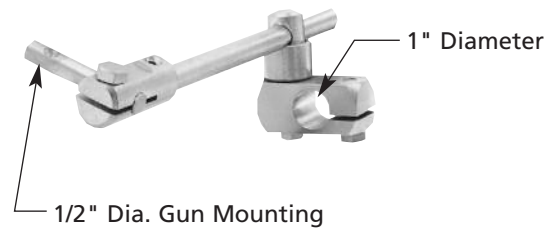

FLUID NOZZLE, NEEDLE, AND AIR CAP COMPATIBILITY

STAINLESS STEEL FLUID NOZZLE DESIGNATION	STAINLESS STEEL FLUID NOZZLE PART NUMBER	STAINLESS STEEL FLUID NEEDLE DESIGNATION	STAINLESS STEEL FLUID NEEDLE PART NUMBER	COMPATIBLE AIR CAPS	AIR CAP PART NUMBER
62SS	45-6201	762	47-760	63P 63PB 63PR 66PH 66SD 66SD-3 66SK	46-6000 46-6002 46-6079 46-6016 46-6020 46-6092 46-6082
63ASS	45-6311	763A	47-763	63P 63PB 63PR 66PH 66SD 66SD-3 66SK	46-6000 46-6002 46-6079 46-6016 46-6020 46-6092 46-6082
63BSS	45-6321	763A	47-763	63P 63PB 200 201 63PR	46-6000 46-6002 46-2200 Tip and 54-1583 Base, 54-1584 ring 46-220 Tip and 54-1583 Base, 54-1584 Ring 46-6079
63CSS	45-6331	763A	47-763	63P 63PB 200 201	46-6000 46-6002 46-2200 Tip and 54-1583 Base, 54-1584 Ring 46-2201 Tip and 54-1583 Base, 54-1584 Ring

Continued on next page.

FLUID NOZZLE, NEEDLE, AND AIR CAP COMPATIBILITY (cont.)

STAINLESS STEEL FLUID NOZZLE DESIGNATION	STAINLESS STEEL FLUID NOZZLE PART NUMBER	STAINLESS STEEL FLUID NEEDLE DESIGNATION	STAINLESS STEEL FLUID NEEDLE PART NUMBER	COMPATIBLE AIR CAPS	AIR CAP PART NUMBER
66SS	45-6601	765	47-765	63P 63PB 63PR 66PD 66PE 66PH 66R 66S 66SD 66SD-3 66SK	46-6000 46-6002 46-6079 46-6013 46-6014 46-6016 46-6041 46-6018 46-6020 46-6092 46-6082
67SS	45-6701	767	47-766	67PB 67PD 706 709SS	46-6101 46-6028 46-2013 Tip and 54-372 Base 46-2020 Tip and 54-372 Base
68SS	45-6801	768	47-768	68PB 201 206 706 709SS	46-6032 46-2206 Tip and 54-1583 Base, 54-1584 Ring 46-2206 Tip and 54-1583 Base, 54-1584 Ring 46-2013 Tip and 54-1583 Base, 54-1584 Ring 46-2020 Tip and 54-372 Base
59ASS	45-5911	759	47-75900	244	46-2244 Tip and 54-2065 Ring
59BSS	45-5912	759	47-75900	250 252	46-2250 Tip and 54-2065 Ring 46-2252 Tip and 54-2065 Ring
59CSS	45-5913	759	47-75900	262	46-2262 Tip and 54-2065 Ring
L6SS	45-6605	759	47-75900	63P 63PB 66PD 66PE 66PH 66S 66SK	46-6000 46-6002 46-6013 46-6014 46-6016 46-6018 46-6082
63CVT	45-6332	763VT	47-762	63P 63PB 63PR 200	46-6000 46-6002 46-6079 46-2200 Tip and 54-1583 Base, 54-1584 Ring
67VT	45-6702	767VT	47-767	67PB 67PD 206 706 709SS	46-6026 46-6028 46-2206 Tip and 54-1583 Base, 54-1584 Ring 46-2013 Tip and 54-372 Base 46-2020 Tip and 54-372 Base
68VT	45-6802	768VT	47-769	68PB 201 206 706 709SS	46-6032 46-2201 Tip and 54-1583 Base, 54-1584 Ring 46-2206 Tip and 54-1583 Base, 54-1584 Ring 46-2013 Tip and 54-372 Base 46-2020 Tip and 54-372 Base

NOTES

NOTES

WARRANTY

This product is covered by Binks' 1 Year Limited Warranty.

Binks Sales and Service: www.binks.com

BINKS

U.S.A./Canada Customer Service
195 Internationale Blvd.
Glendale Heights, IL 60139
630-237-5000

Toll Free Customer Service
and Technical Support
800-992-4657
Toll Free Fax
888-246-5732

77-2641R-14 Revisions: Trademark updates.